

VX Series

Diesel and LP Gas Forklift Trucks

2,000kg, 2,500kg, 3,000kg and 3,500kg



- Intellix Vehicle Management System
- 3 application matched transmissions, including the World's best hydrodynamic transmission - the Yale Techtronix 200X
- Oil immersed brakes
- ADS - Auto Deceleration System on Techtronix 100 transmission
- Anti Roll Back
- CANbus technology
- Accutouch minilevers, PalmTech joystick and manual levers
- Supercushion, pneumatic and Michelin XZM radial tyres

Yale 
People. Products. Productivity.

Truck Dimensions

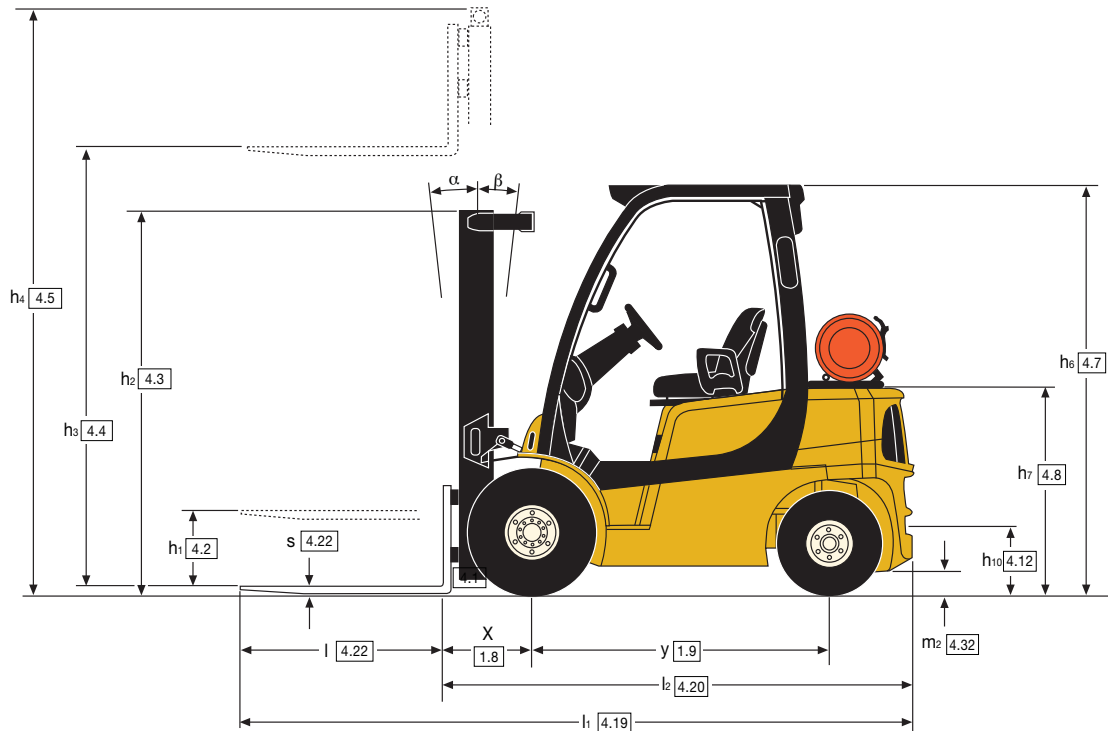
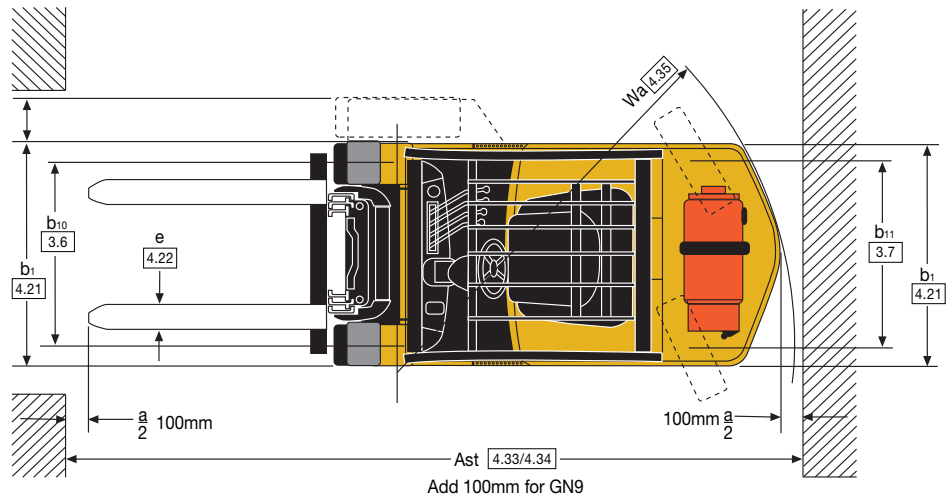

Engine Specifications

Yanmar TNE series, Diesel

Base, Value, Productivity

4 Cylinder	Overhead valve
Displacement	2.6 litre
Torque	146 Nm @ 1,400rpm
Power	35.8kW @ 2,450rpm
Air filtration	Two stage, dry type
IDI fuel injection system	

Yanmar TNE series, Diesel

Base, Value, Productivity

4 Cylinder	Overhead valve
Displacement	3.3 litre
Torque	210 Nm @ 1,700rpm
Power	48.5 kW @ 2,400rpm
Air filtration	Two stage, dry type
IDI fuel injection system	

Mazda FE, LPG - Base

4 Cylinder	Overhead Camshaft
Displacement	2.0 litre
Torque	124 Nm @ 1,800rpm
Power	32.8 kW @ 2,700rpm
Air filtration	Two stage, dry type
Emission Control Closed loop	

Mazda F2, LPG - Value

4 Cylinder	Overhead Camshaft
Displacement	2.2 litre
Torque	146 Nm @ 1,800rpm
Power	38 kW @ 2,700rpm
Air filtration	Two stage, dry type
Emission Control Closed loop	

GM, LPG - Productivity

4 Cylinder	Overhead Camshaft
Displacement	2.4 litre
Torque	167 Nm @ 2,650rpm
Power	46.2 kW @ 2,700rpm
Air filtration	Two stage, dry type
Emission Control Closed loop	

Options

- Powertrain protection system
- Premium monitoring package
- High air intake with pre-cleaner
- Accumulator
- Keyless start (with auxiliary key switch)
- Traction speed limiter
- Heavy-duty "Combi Cooler" radiator
- Swing-out, drop-down EZ-Tank bracket
- Return-to-set tilt
- Swivel full suspension seat
- Foot directional control
- Operator password
- Alarm-reverse
- Amber strobe light - continuous activated
- Impact monitor
- Load weight indicator
- Oil immersed brakes

A full range of Yale Hi-Vis™ 2 stg LFL and 2 and 3 stage FFL masts are available.

Yale Hi-Vis™ masts are designed for maximum visibility, with widely spaced channels, lift chains and main lift cylinders.

Mast details and capacity ratings (kg) - Supercushion tyres

Model		GLP/GDP 20 VX										GLP/GDP 25 VX						
Tyres		7.00 x 12										7.00 x 12						
Width across tyres		1157mm										1157mm						
Mast	OAH h1	FFH h2+s	MFH h3+s	h4	Tilt		Forks			Integral side shift			Forks			Integral side shift		
					F	B	500	600	700	500	600	700	500	600	700	500	600	700
					LC	LC	LC	LC	LC	LC	LC	LC	LC	LC	LC	LC	LC	LC
2-Stg. LFL (V)	2170	140	3290	3904	6	5	2000	1920	1760	2000	1840	1690	2500	2380	2180	2500	2280	2100
	2420	140	3790	4404	6	5	2000	1910	1750	2000	1830	1680	2500	2370	2170	2500	2280	2090
	2770	140	4330	4944	6	5	2000	1900	1730	2000	1820	1670	2500	2350	2150	2480	2260	2070
2-Stg. FFL (F)	2170	1558	3300	3914	6	5	2000	1920	1760	2000	1850	1690	2500	2380	2180	2500	2290	2100
3-Stg. FFL (E)	1970	1382	4350	4938	6	5	2000	1880	1720	1980	1800	1650	2500	2380	2180	2500	2280	2090
	2170	1582	4950	5538	6	5	1880	1770	1610	1860	1680	1540	2380	2240	2060	2380	2150	1970
	2420	1832	5550	6138	6	5	1770	1630	1500	1720	1560	1430	2240*	2110*	1930*	2220*	2020*	1860*

* With wide tread drive tyres (1317mm width) or dual drive tyres (1601mm width) - must be specified. h2 and h4 are without load backrest.

Mast details and capacity ratings (kg) - Supercushion tyres

Model		GLP/GDP 30 VX										GLP/GDP 35 VX						
Tyres		7.00 x 12										7.00 x 12						
Width across tyres		1186mm										1186mm						
Mast	OAH h1	FFH h2+s	MFH h3+s	h4	Tilt		Forks			Integral side shift			Forks			Integral side shift		
					F	B	500	600	700	500	600	700	500	600	700	500	600	700
					LC	LC	LC	LC	LC	LC	LC	LC	LC	LC	LC	LC	LC	LC
2-Stg. LFL (V)	2195	150	3105	3809	6	5	3000	2820	2580	2960	2700	2480	3500	3030	3310	3490	3180	2910
	2445	150	3605	4309	6	5	3000	2810	2570	2950	2690	2470	3500	3020	3300	3480	3170	2910
	2795	150	4105	4809	6	5	3000	2790	2560	2930	2670	2450	3500	3010	3280	3460	3150	2890
2-Stg. FFL (F)	2195	1495	3110	3810	6	5	3000	2820	2580	2960	2700	2480	3500	3030	3310	3490	3170	2910
3-Stg. FFL (E)	1995	1319	4015	4694	6	5	3000	2800	2560	2930	2670	2450	3500	3010	3290	3450	3150	2890
	2195	1519	4615	5294	6	5	2900	2700	2470	2830	2590	2360	3400	2930	3200	3360	3040	2790
	2345	1669	4915	5594	6	5	2830	2630	2400	2740	2520	2310	3330*	2860*	3110*	3270*	2970*	2720*
	2445	1769	5215	5894	6	5	2740	2560	2340	2680	2450	2240	3240*	2770*	3040*	3170*	2900*	2650*

* With wide tread drive tyres (1321mm width) or dual drive tyres (1601mm width) - must be specified. h2 and h4 without load backrest.

Mast details and capacity ratings (kg) - Michelin XZM tyres

Model		GLP/GDP 20 VX										GLP/GDP 25 VX						
Tyres		7.00 x 12										7.00 x 12						
Width across tyres		1157mm										1157mm						
Mast	OAH h1	FFH h2+s	MFH h3+s	h4	Tilt		Forks			Integral side shift			Forks			Integral side shift		
					F	B	500	600	700	500	600	700	500	600	700	500	600	700
					LC	LC	LC	LC	LC	LC	LC	LC	LC	LC	LC	LC	LC	LC
2-Stg. LFL (V)	2170	140	3290	3904	6	10	2000	1920	1760	2000	1840	1690	2500	2380	2180	2500	2280	2100
	2420	140	3790	4404	6	10	2000	1910	1750	2000	1830	1680	2500	2370	2170	2500	2280	2090
	2770	140	4330	4944	6	5	2000	1900	1730	2000	1820	1670	2500	2350	2150	2480	2260	2070
2-Stg. FFL (F)	2170	1558	3300	3914	6	10	2000	1920	1760	2000	1850	1690	2500	2380	2180	2500	2290	2100
3-Stg. FFL (E)	1970	1382	4350	4938	6	5	2000	1880	1720	*1980	1800	1650	*2500	*2380	*2180	*2500	*2280	*2090
	2170	1582	4950	5538	6	5	*1880	*1770	*1610	*1860	*1680	*1540	*2380	*2240	*2060	*2380	*2150	*1970
	2420	1832	5550	6138	6	5	*1770	*1630	*1500	*1720	*1540	*1430	**2240	**2110	**1930	**2220	**2020	**1860

* With wide tread drive tyres (1317mm width) or dual drive tyres (1601mm width) - must be specified. **Dual drive tyres (1601mm width) must be specified. h2 and h4 are without load backrest.

Mast details and capacity ratings (kg) - Michelin XZM tyres

Model		GLP/GDP 30 VX										GLP/GDP 35 VX						
Tyres		7.00 x 12										7.00 x 12						
Width across tyres		1186mm										1186mm						
Mast	OAH h1	FFH h2+s	MFH h3+s	h4	Tilt		Forks			Integral side shift			Forks			Integral side shift		
					F	B	500	600	700	500	600	700	500	600	700	500	600	700
					LC	LC	LC	LC	LC	LC	LC	LC	LC	LC	LC	LC	LC	LC
2-Stg. LFL (V)	2195	150	3105	3809	6	10	3000	2820	2580	2960	2700	2480	3500	3310	3030	3490	3180	2910
	2445	150	3605	4309	6	10	3000	2810	2570	2950	2690	2470	3500	3300	3020	3480	3170	2910
	2795	150	4105	4809	6	5	3000	2790	2560	2930	2670	2450	3500	3280	3010	3460	3150	2890
2-Stg. FFL (F)	2195	1495	3110	3810	6	10	3000	2820	2580	2960	2700	2480	3500	3310	3030	3490	3170	2910
3-Stg. FFL (E)	1995	1319	4015	4694	6	5	3000	2800	2560	2930	2670	2450	*3500	*3290	*3010	*3450	*3150	*2890
	2195	1519	4615	5294	6	5	*2900	*2700	*2470	*2830	*2590	*2360	*3400	*3170	*2930	*3330	*3040	*2790
	2345	1669	4915	5594	6	5	*2830	*2630	*2400	*2740	*2520	*2310	**3330	**3110	**2860	**3270	*2970	**2720
	2445	1769	5215	5894	6	5	*2720	*2560	*2340	*2680	*2430	*2240	**3270	**3040	**2790	**3170*	**2900	**2680

* With wide tread drive tyres (1321mm width) or dual drive tyres (1601mm width) - must be specified. *Dual drive tyres (1601mm width) must be specified. h2 and h4 without load backrest.

VDI 2198 – General Specifications, Diesel Powered GDP20VX, GDP25VX

		Yale			
		GDP 20 VX			
		Yanmar 2.6L Standard Electronic	Yanmar 2.6L Techtronix 100	Yanmar 3.3L Techtronix 200	
		Base	Value	Productivity	
Characteristics	1.1	Manufacturer			
	1.2	Model designation			
		Power Train - Engine Transmission	Yanmar 2.6L Standard Electronic	Yanmar 2.6L Techtronix 100	Yanmar 3.3L Techtronix 200
		Model - Manufacturer Designation	Base	Value	Productivity
	1.3	Drive: Diesel, LPG	Diesel	Diesel	Diesel
	1.4	Operation: Seated rider	Seated Rider	Seated Rider	Seated Rider
	1.5	Load capacity	Q (kg)	2000	2000
	1.6	Load centre	c (mm)	500	500
	1.8	Load distance	x (mm)	471	471
1.9	Wheelbase	y (mm)	1623	1623	
Weights	2.1	Unladen weight	kg	3688	
	2.2	Axle loading laden, front/rear	kg	5103 / 584	
	2.3	Axle loading unladen, front/rear	kg	1907 / 1781	
Wheels & Tyres	3.1	Tyres: P=pneumatic, C=cushion, SC=supercushion	SC	SC	
	3.2	Tyre size-front	7.00 X 12 - 12	7.00 X 12 - 12	
	3.3	Tyre size-rear	6.00 X 9	6.00 X 9	
	3.5	Number of wheels, front/rear (X = driven)	2x / 2	2x / 2	
	3.6	Track width, front	b10 (mm)	965	
	3.7	Track width, rear	b11 (mm)	967	
	Dimensions	4.1	Mast tilt, forward α /back β	degrees	6 / 5
4.2		Height of mast, lowered	h1 (mm)	2170	
4.3		Free lift ▲	h2 (mm)	100	
4.4		Lift height ▲	h3 (mm)	3250	
4.5		Height of mast, extended †	h4 (mm)	3904	
4.7		Height to top of overhead guard ○	h6 (mm)	2160	
4.8		Seat height ✕	h7 (mm)	1061	
4.12		Towing coupling height	h10 (mm)	365	
4.19		Overall length	l1 (mm)	3486	
4.20		Length to face of forks	l2 (mm)	2486	
4.21		Overall width, Std/Dual	b1/b2 (mm)	1157 / 1601	
4.22		Fork dimensions	s/e/l (mm)	40 X 100 X 1000	
4.23		Fork carriage to DIN 15173. Class, A/B	II A	II A	
4.24		Fork carriage width ▶	b3 (mm)	1067	
4.31		Ground clearance under mast, laden	m1 (mm)	107	
4.32		Ground clearance at centre of wheelbase	m2 (mm)	160	
4.33		Aisle width with pallets 1000 long x 1200 wide,	Ast (mm)	3919	
4.34		Aisle width with pallets 800 wide x 1200 long,	Ast (mm)	4056	
4.35		Outer turning radius	Wa (mm)	2149	
4.36		Inner turning radius	b13 (mm)	50	
Performance	5.1	Travel speed laden/unladen	km/h	16.9 / 18.0	
	5.2	Lifting speed laden/unladen	m/sec	0.66 / 0.71	
	5.3	Lowering speed laden/unladen	m/sec	0.50 / 0.42	
	5.5	Maximum drawbar pull laden/unladen,	N	21204 / 11570	
		Drawbar pull laden/unladen, @ 1.6km/h	N	17440 / 11570	
		Drawbar pull laden/unladen, @ 4.8km/h	N	11600 / 11800	
	5.7	Gradeability laden/unladen, @ 1.6km/h	%	33.2 / 34.2	
		Gradeability laden/unladen, @ 4.8km/h	%	21.3 / 34.2	
	5.10	Service brake	Hydraulic	Hydraulic	
	Motor	7.1	Engine manufacturer/type	Yanmar 4TNE92	Yanmar 4TNE92
7.2		Engine output, in accordance with ISO1585	kW	35.8	
7.3		Governed speed	rpm	2700	
7.4		Number of cylinders/displacement	cm3	4 / 2659	
Other	8.1	Drive control	Hydrodynamic	Hydrodynamic	
	8.2	Working pressure for attachments	bar	0 - 155	
	8.3	Oil flow for attachments †	l/min	75	
	8.4	Average noise level at operator's ear ★	dB(A)	80	
		Guaranteed sound power 2001/14/EC		104	
8.5	Towing coupling type	Pin	Pin		

★ Measured according to the test cycles and based on the weighting values contained in EN12053.

† Variable

▲ Top of forks

✕ Full suspension seat in depressed position

▶ Add 32mm with load backrest

○ h6 subject to +/- 5mm tolerance

† Without load backrest

Specification sheet truck based on:

(GDP 20 VX and GDP 25 VX) 3290mm of 2 stage LFL mast with standard carriage, 1000mm forks and e-hydraulics.

	Yale					1.1
	GDP 25 VX					1.2
Yanmar 3.3L Techtronix 200X	Yanmar 2.6L Standard Electronic	Yanmar 3.3L Standard Electronic	Yanmar 2.6L Techtronix 100	Yanmar 3.3L Techtronix 100	Yanmar 3.3L Techtronix 200X	
Productivity	Base	Base	Value	Productivity	Productivity	
Diesel	Diesel	Diesel	Diesel	Diesel	Diesel	1.3
Seated Rider	Seated Rider	Seated Rider	Seated Rider	Seated Rider	Seated Rider	1.4
2000	2500	2500	2500	2500	2500	1.5
500	500	500	500	500	500	1.6
471	471	471	471	471	471	1.8
1623	1623	1623	1623	1623	1623	1.9
3688	4026	4026	4026	4026	4026	2.1
5103 / 584	5833 / 693	5833 / 693	5833 / 693	5833 / 693	5833 / 693	2.2
1907 / 1781	1837 / 2189	1837 / 2189	1837 / 2189	1837 / 2189	1837 / 2189	2.3
SC	SC	SC	SC	SC	SC	3.1
7.00 X 12 - 12	7.00 X 12 - 12	7.00 X 12 - 12	7.00 X 12 - 12	7.00 X 12 - 12	7.00 X 12 - 12	3.2
6.00 X 9	6.00 X 9	6.00 X 9	6.00 X 9	6.00 X 9	6.00 X 9	3.3
2x / 2	2x / 2	2x / 2	2x / 2	2x / 2	2x / 2	3.5
965	965	965	965	965	965	3.6
967	967	967	967	967	967	3.7
6 / 5	6 / 5	6 / 5	6 / 5	6 / 5	6 / 5	4.1
2170	2170	2170	2170	2170	2170	4.2
100	100	100	100	100	100	4.3
3250	3250	3250	3250	3250	3250	4.4
3904	3904	3904	3904	3904	3904	4.5
2160	2160	2160	2160	2160	2160	4.7
1061	1061	1061	1061	1061	1061	4.8
365	365	365	365	365	365	4.12
3486	3559	3559	3559	3559	3559	4.19
2486	2559	2559	2559	2559	2559	4.20
1157 / 1601	1157 / 1601	1157 / 1601	1157 / 1601	1157 / 1601	1157 / 1601	4.21
40 X 100 X 1000	40 X 100 X 1000	40 X 100 X 1000	40 X 100 X 1000	40 X 100 X 1000	40 X 100 X 1000	4.22
II A	II A	II A	II A	II A	II A	4.23
1067	1067	1067	1067	1067	1067	4.24
107	107	107	107	107	107	4.31
160	160	160	160	160	160	4.32
3919	3986	3986	3986	3986	3986	4.33
4056	4123	4123	4123	4123	4123	4.34
2149	2216	2216	2216	2216	2216	4.35
50	50	50	50	50	50	4.36
21.1 / 21.4	16.9 / 18.0	18.2 / 19.3	16.9 / 18.0	18.2 / 19.3	21.1 / 21.4	5.1
0.68 / 0.68	0.61 / 0.71	0.68 / 0.68	0.61 / 0.71	0.68 / 0.68	0.68 / 0.68	5.2
0.50 / 0.42	0.50 / 0.42	0.50 / 0.42	0.50 / 0.42	0.50 / 0.42	0.50 / 0.42	5.3
21805 / 11570	19389 / 11450	24248 / 11450	19389 / 11450	24248 / 11450	21805 / 11450	5.5
21805 / 11570	17440 / 11450	21640 / 11450	17440 / 11450	21640 / 11450	21805 / 11450	
20000 / 20900	11800 / 11100	16500 / 16500	11800 / 11100	16500 / 16500	20900 / 19600	
42.8 / 34.2	27.7 / 29.3	35.1 / 29.3	27.7 / 29.3	35.1 / 29.3	35.4 / 29.3	5.7
39.0 / 34.2	21.0 / 29.3	26.0 / 29.3	21.0 / 29.3	26.0 / 29.3	33.8 / 29.3	
Hydraulic	Hydraulic	Hydraulic	Hydraulic	Hydraulic	Hydraulic	5.10
Yanmar 4TNE98	Yanmar 4TNE92	Yanmar 4TNE98	Yanmar 4TNE92	Yanmar 4TNE98	Yanmar 4TNE98	7.1
48.5	35.8	48.5	35.8	48.5	48.5	7.2
2600	2700	2600	2700	2600	2600	7.3
4 / 3319	4 / 2659	4 / 3319	4 / 2659	4 / 3319	4 / 3319	7.4
Hydrodynamic	Hydrodynamic	Hydrodynamic	Hydrodynamic	Hydrodynamic	Hydrodynamic	8.1
0 - 155	0 - 155	0 - 155	0 - 155	0 - 155	0 - 155	8.2
75	75	75	75	75	75	8.3
80	80	80	80	80	80	8.4
104	104	104	104	104	104	
Pin	Pin	Pin	Pin	Pin	Pin	8.5

Specification sheet truck based on:

GDP 30 VX and GDP 35 VX 3105mm tof 2 stage LFL mast with standard carriage, 1000mm forks and e-hydraulics.

VDI 2198 – General Specifications, Diesel Powered GDP30VX, GDP35VX

		Yale				
		GDP 30 VX				
		Yanmar 2.6L Standard Electronic	Yanmar 3.3L Standard Electronic	Yanmar 2.6L Techtronix 100		
		Base	Base	Value		
Characteristics	1.1	Manufacturer				
	1.2	Model designation				
		Power Train - Engine Transmission				
		Model - Manufacturer Designation				
	1.3	Drive: Diesel, LPG	Diesel	Diesel	Diesel	
	1.4	Operation: Seated rider	Seated Rider	Seated Rider	Seated Rider	
	1.5	Load capacity	Q (kg)	3000	3000	
	1.6	Load centre	c (mm)	500	500	
	1.8	Load distance	x (mm)	478	478	
1.9	Wheelbase	y (mm)	1623	1623		
Weights	2.1	Unladen weight	kg	4505	4505	4505
	2.2	Axle loading laden, front/rear	kg	6725 / 781	6725 / 781	6725 / 781
	2.3	Axle loading unladen, front/rear	kg	1907 / 2598	1907 / 2598	1907 / 2598
Wheels & Tyres	3.1	Tyres: P=pneumatic, C=cushion, SC=supercushion		SC	SC	SC
	3.2	Tyre size-front		28 X 9 - 15	28 X 9 - 15	28 X 9 - 15
	3.3	Tyre size-rear		6.50 X 10	6.50 X 10	6.50 X 10
	3.5	Number of wheels, front/rear (X = driven)		2x / 2	2x / 2	2x / 2
	3.6	Track width, front	b10 (mm)	965	965	965
	3.7	Track width, rear	b11 (mm)	967	967	967
	Dimensions	4.1	Mast tilt, forward α /back β	degrees	6 / 5	6 / 5
4.2		Height of mast, lowered	h1 (mm)	2195	2195	2195
4.3		Free lift ▲	h2 (mm)	100	100	100
4.4		Lift height ▲	h3 (mm)	3055	3055	3055
4.5		Height of mast, extended †	h4 (mm)	3809	3809	3809
4.7		Height to top of overhead guard ○	h6 (mm)	2185	2185	2185
4.8		Seat height ✕	h7 (mm)	1086	1086	1086
4.12		Towing coupling height	h10 (mm)	390	390	390
4.19		Overall length	l1 (mm)	3633	3633	3633
4.20		Length to face of forks	l2 (mm)	2633	2633	2633
4.21		Overall width, Standard/Dual	b1/b2 (mm)	1186 / 1601	1186 / 1601	1186 / 1601
4.22		Fork dimensions	s/e/l (mm)	50 X 125 X 1000	50 X 125 X 1000	50 X 125 X 1000
4.23		Fork carriage to DIN 15173. Class, A/B		III A	III A	III A
4.24		Fork carriage width ▶	b3 (mm)	1067	1067	1067
4.31		Ground clearance under mast, laden	m1 (mm)	132	132	132
4.32		Ground clearance at centre of wheelbase	m2 (mm)	185	185	185
4.33	Aisle width with pallets 1000 long x 1200 wide	Ast (mm)	4063	4063	4063	
4.34	Aisle width with pallets 800 wide x 1200 long	Ast (mm)	4196	4196	4196	
4.35	Outer turning radius	Wa (mm)	2277	2277	2277	
4.36	Inner turning radius	b13 (mm)	25	25	25	
Performance	5.1	Travel speed laden/unladen	km/h	18.2 / 19.1	20.0 / 21.1	18.2 / 19.2
	5.2	Lifting speed laden/unladen	m/sec	0.47 / 0.62	0.60 / 0.60	0.47 / 0.62
	5.3	Lowering speed laden/unladen	m/sec	0.50 / 0.42	0.50 / 0.42	0.50 / 0.42
	5.5	Maximum drawbar pull laden/unladen	N	19291 / 11708	24164 / 13154	19291 / 11708
		Drawbar pull laden/unladen, @ 1.6km/h	N	16354 / 11708	21556 / 13154	16354 / 11708
		Drawbar pull laden/unladen, @ 4.8km/h	N	11100 / 11600	16200 / 16500	11100 / 11600
	5.7	Gradeability laden/unladen, @ 1.6km/h	%	22.6 / 26.6	30.3 / 30.2	22.6 / 26.6
		Gradeability laden/unladen, @ 4.8km/h	%	15.0 / 26.6	23.0 / 30.2	15.0 / 26.6
	5.10	Service brake		Hydraulic	Hydraulic	Hydraulic
	Motor	7.1	Engine manufacturer/type		Yanmar 4TNE92	Yanmar 4TNE98
7.2		Engine output, in accordance with ISO1585	kW	35.8	48.5	35.8
7.3		Governed speed	rpm	2700	2600	2700
7.4		Number of cylinders/displacement	cm3	4 / 2659	4 / 3319	4 / 2659
Other	8.1	Drive control		Hydrodynamic	Hydrodynamic	Hydrodynamic
	8.2	Working pressure for attachments	bar	0 - 155	0 - 155	0 - 155
	8.3	Oil flow for attachments †	l/min	75	75	75
	8.4	Average noise level at operator's ear ★	dB(A)	80	80	80
		Guaranteed sound power 2001/14/EC		104	104	104
8.5	Towing coupling type		Pin	Pin	Pin	

★ Measured according to the test cycles and based on the weighting values contained in EN12053.

† Variable

▲ Top of forks

✕ Full suspension seat in depressed position

▶ Add 32mm with load backrest

○ h6 subject to +/- 5mm tolerance

† Without load backrest

Specification sheet truck based on:

GDP 30 VX and GDP 35 VX 3105mm tof 2 stage LFL mast with standard carriage, 1000mm forks and e-hydraulics.

		Yale				1.1	Characteristics
		GDP 35 VX				1.2	
Yanmar 3.3L Techtronix 100	Yanmar 3.3L Techtronix 200X	Yanmar 3.3L Standard Electronic	Yanmar 3.3L Techtronix 100	Yanmar 3.3L Techtronix 100	Yanmar 3.3L Techtronix 200X		
Productivity	Productivity	Base	Value	Productivity	Productivity		
Diesel	Diesel	Diesel	Diesel	Diesel	Diesel	1.3	
Seated Rider	Seated Rider	Seated Rider	Seated Rider	Seated Rider	Seated Rider	1.4	
3000	3000	3500	3500	3500	3500	1.5	
500	500	500	500	500	500	1.6	
478	478	478	478	478	478	1.8	
1623	1623	1700	1700	1700	1700	1.9	
4505	4505	4816	4816	4816	4816	2.1	
6725 / 781	6725 / 781	7392 / 925	7392 / 925	7392 / 925	7392 / 925	2.2	
1907 / 2598	1907 / 2598	1868 / 2948	1868 / 2948	1868 / 2948	1868 / 2948	2.3	
SC	SC	SC	SC	SC	SC	3.1	
28 X 9 - 15	28 X 9 - 15	28 X 9 - 15	28 X 9 - 15	28 X 9 - 15	28 X 9 - 15	3.2	
6.50 X 10	6.50 X 10	6.50 X 10	6.50 X 10	6.50 X 10	6.50 X 10	3.3	
2x / 2	2x / 2	2x / 2	2x / 2	2x / 2	2x / 2	3.5	
965	965	965	965	965	965	3.6	
967	967	967	967	967	967	3.7	
6 / 5	6 / 5	6 / 5	6 / 5	6 / 5	6 / 5	4.1	
2195	2195	2195	2195	2195	2195	4.2	
100	100	100	100	100	100	4.3	
3055	3055	3055	3055	3055	3055	4.4	
3809	3809	3809	3809	3809	3809	4.5	
2185	2185	2185	2185	2185	2185	4.7	
1086	1086	1086	1086	1086	1086	4.8	
390	390	390	390	390	390	4.12	
3633	3633	3734	3734	3734	3734	4.19	
2633	2633	2734	2734	2734	2734	4.20	
1186 / 1601	1186 / 1601	1186 / 1601	1186 / 1601	1186 / 1601	1186 / 1601	4.21	
50 X 125 X 1000	50 X 125 X 1000	50 X 125 X 1000	50 X 125 X 1000	50 X 125 X 1000	50 X 125 X 1000	4.22	
III A	III A	III A	III A	III A	III A	4.23	
1067	1067	1067	1067	1067	1067	4.24	
132	132	132	132	132	132	4.31	
185	185	185	185	185	185	4.32	
4063	4063	4156	4156	4156	4156	4.33	
4196	4196	4293	4293	4293	4293	4.34	
2277	2277	2380	2380	2380	2380	4.35	
25	25	54	54	54	54	4.36	
20.0 / 21.1	22.4 / 22.7	20.0 / 21.1	20.0 / 21.1	20.0 / 21.1	22.4 / 22.7	5.1	
0.60 / 0.60	0.60 / 0.60	0.60 / 0.60	0.60 / 0.60	0.60 / 0.60	0.60 / 0.60	5.2	
0.50 / 0.42	0.50 / 0.42	0.50 / 0.42	0.50 / 0.42	0.50 / 0.42	0.50 / 0.42	5.3	
24164 / 13154	21805 / 11708	24079 / 11708	24079 / 11708	24079 / 11708	21805 / 12594	5.5	
21556 / 13154	21805 / 11708	21485 / 11708	21485 / 11708	21485 / 11708	21805 / 12594		
16200 / 16500	19600 / 19400	16500 / 16500	16500 / 16500	16500 / 16500	19100 / 19400		
30.3 / 30.2	30.4 / 26.6	30.5 / 26.6	30.5 / 26.6	30.5 / 26.6	27.3 / 26.9	5.7	
23.0 / 30.2	26.1 / 26.6	20.2 / 26.6	20.2 / 26.6	20.2 / 26.6	24.0 / 26.9		
Hydraulic	Hydraulic	Hydraulic	Hydraulic	Hydraulic	Hydraulic	5.10	
Yanmar 4TNE98	Yanmar 4TNE98	Yanmar 4TNE98	Yanmar 4TNE98	Yanmar 4TNE98	Yanmar 4TNE98	7.1	
48.5	48.5	48.5	48.5	48.5	48.5	7.2	
2600	2600	2600	2600	2600	2600	7.3	
4 / 3319	4 / 3319	4 / 3319	4 / 3319	4 / 3319	4 / 3319	7.4	
Hydrodynamic	Hydrodynamic	Hydrodynamic	Hydrodynamic	Hydrodynamic	Hydrodynamic	8.1	
0 - 155	0 - 155	0 - 155	0 - 155	0 - 155	0 - 155	8.2	
75	75	75	75	75	75	8.3	
80	80	80	80	80	80	8.4	
104	104	104	104	104	104		
Pin	Pin	Pin	Pin	Pin	Pin	8.5	

Specification sheet truck based on:
GDP 20 VX and GDP 25 VX 3290mm tof 2 stage LFL mast with standard carriage, 1000mm forks and e-hydraulics.

VDI 2198 – General Specifications, LPG Powered GLP20VX, GLP25VX

		Yale				
		GLP 20 VX				
Characteristics	1.1	Manufacturer				
	1.2	Model designation				
		Power Train - Engine Transmission		Mazda 2.0L Standard Electronic	Mazda 2.2L Standard Electronic	Mazda 2.2L Techtronix 100
		Model - Manufacturer Designation		Base	Base	Value
	1.3	Drive: Diesel, LPG		LPG	LPG	LPG
	1.4	Operation: Seated rider		Seated Rider	Seated Rider	Seated Rider
	1.5	Load capacity	Q (kg)	2000	2000	2000
	1.6	Load centre	c (mm)	500	500	500
	1.8	Load distance	x (mm)	471	471	471
1.9	Wheelbase	y (mm)	1623	1623	1623	
Weights	2.1	Unladen weight	kg	3688	3688	3688
	2.2	Axle loading laden, front/rear	kg	5103 / 584	5103 / 584	5103 / 584
	2.3	Axle loading unladen, front/rear	kg	1907 / 1781	1907 / 1781	1907 / 1781
Wheels & Tyres	3.1	Tyres: P=pneumatic, C=cushion, SC=supercushion		SC	SC	SC
	3.2	Tyre size-front		7.00 X 12 - 12	7.00 X 12 - 12	7.00 X 12 - 12
	3.3	Tyre size-rear		6.00 X 9	6.00 X 9	6.00 X 9
	3.5	Number of wheels, front/rear (X = driven)		2x / 2	2x / 2	2x / 2
	3.6	Track width, front	b10 (mm)	965	965	965
	3.7	Track width, rear	b11 (mm)	967	967	967
	Dimensions	4.1	Mast tilt, forward α /back β	degrees	6 / 5	6 / 5
4.2		Height of mast, lowered	h1 (mm)	2170	2170	2170
4.3		Free lift ▲	h2 (mm)	100	100	100
4.4		Lift height ▲	h3 (mm)	3250	3250	3250
4.5		Height of mast, extended †	h4 (mm)	3904	3904	3904
4.7		Height to top of overhead guard ○	h6 (mm)	2160	2160	2160
4.8		Seat height ✕	h7 (mm)	1061	1061	1061
4.12		Towing coupling height	h10 (mm)	365	365	365
4.19		Overall length	l1 (mm)	3486	3486	3486
4.20		Length to face of forks	l2 (mm)	2486	2486	2486
4.21		Overall width, Std/Dual	b1/b2 (mm)	1157 / 1601	1157 / 1601	1157 / 1601
4.22		Fork dimensions	s/e/l (mm)	40 X 100 X 1000	40 X 100 X 1000	40 X 100 X 1000
4.23		Fork carriage to DIN 15173. Class, A/B		II A	II A	II A
4.24		Fork carriage width ▶	b3 (mm)	1067	1067	1067
4.31		Ground clearance under mast, laden	m1 (mm)	107	107	107
4.32		Ground clearance at centre of wheelbase	m2 (mm)	160	160	160
4.33		Aisle width with pallets 1000 long x 1200 wide,	Ast (mm)	3919	3919	3919
4.34		Aisle width with pallets 800 wide x 1200 long,	Ast (mm)	4056	4056	4056
4.35		Outer turning radius	Wa (mm)	2149	2149	2149
4.36	Inner turning radius	b13 (mm)	50	50	50	
Performance	5.1	Travel speed laden/unladen	km/h	17.1 / 18.0	17.1 / 18.0	17.1 / 18.0
	5.2	Lifting speed laden/unladen	m/sec	0.56 / 0.57	0.56 / 0.57	0.56 / 0.57
	5.3	Lowering speed laden/unladen	m/sec	0.50 / 0.42	0.50 / 0.42	0.50 / 0.42
	5.5	Maximum drawbar pull laden/unladen,	N	17257 / 12082	20510 / 12082	20510 / 12082
		Drawbar pull laden/unladen, @ 1.6km/h	N	13991 / 12082	16937 / 12082	16937 / 12082
		Drawbar pull laden/unladen, @ 4.8km/h	N	8800 / 8900	11200 / 11200	11200 / 11200
	5.7	Gradeability laden/unladen, @ 1.6km/h	%	15.0 / 24.5	31.1 / 34.2	31.1 / 34.2
		Gradeability laden/unladen, @ 4.8km/h	%	25.3 / 34.2	19.0 / 29.8	19.0 / 29.8
	5.10	Service brake		Hydraulic	Hydraulic	Hydraulic
	Motor	7.1	Engine manufacturer/type		Mazda FE	Mazda F2
7.2		Engine output, in accordance with ISO1585	kW	32.8	38.0	38.0
7.3		Governed speed	rpm	2700	2700	2700
7.4		Number of cylinders/displacement	cm3	4 / 1998	4 / 2184	4 / 2184
Other	8.1	Drive control		Hydrodynamic	Hydrodynamic	Hydrodynamic
	8.2	Working pressure for attachments	bar	0 - 155	0 - 155	0 - 155
	8.3	Oil flow for attachments †	l/min	62	62	62
	8.4	Average noise level at operator's ear ★	dB(A)	80	80	80
		Guaranteed sound power 2001/14/EC		103	103	103
8.5	Towing coupling type		Pin	Pin	Pin	

★ Measured according to the test cycles and based on the weighting values contained in EN12053.

† Variable

▲ Top of forks

✕ Full suspension seat in depressed position

▶ Add 32mm with load backrest

○ h6 subject to +/- 5mm tolerance

† Without load backrest

Specification sheet truck based on:

GLP 20 VX and GLP 25 VX 3290mm tof 2 stage LFL mast with standard carriage, 1000mm forks and e-hydraulics.

		Yale					1.1	Characteristics
		GLP 25 VX					1.2	
GM 2.4L Techtronix 100	GM 2.4L Techtronix 200X	Mazda 2.0L Standard Electronic	Mazda 2.2L Standard Electronic	Mazda 2.2L Techtronix 100	GM 2.4L Techtronix 100	GM 2.4L Techtronix 200X		
Productivity	Productivity	Base	Base	Value	Productivity	Productivity		
LPG	LPG	LPG	LPG	LPG	LPG	LPG	1.3	
Seated Rider	Seated Rider	Seated Rider	Seated Rider	Seated Rider	Seated Rider	Seated Rider	1.4	
2000	2000	2500	2500	2500	2500	2500	1.5	
500	500	500	500	500	500	500	1.6	
471	471	471	471	471	471	471	1.8	
1623	1623	1623	1623	1623	1623	1623	1.9	
3688	3688	4026	4026	4026	4026	4026	2.1	
5103 / 584	5103 / 584	5833 / 693	5833 / 693	5833 / 693	5833 / 693	5833 / 693	2.2	
1907 / 1781	1907 / 1781	1837 / 2189	1837 / 2189	1837 / 2189	1837 / 2189	1837 / 2189	2.3	
SC	SC	SC	SC	SC	SC	SC	3.1	
7.00 X 12 - 12	7.00 X 12 - 12	7.00 X 12 - 12	7.00 X 12 - 12	7.00 X 12 - 12	7.00 X 12 - 12	7.00 X 12 - 12	3.2	
6.00 X 9	6.00 X 9	6.00 X 9	6.00 X 9	6.00 X 9	6.00 X 9	6.00 X 9	3.3	
2x / 2	2x / 2	2x / 2	2x / 2	2x / 2	2x / 2	2x / 2	3.5	
965	965	965	965	965	965	965	3.6	
967	967	967	967	967	967	967	3.7	
6 / 5	6 / 5	6 / 5	6 / 5	6 / 5	6 / 5	6 / 5	4.1	
2170	2170	2170	2170	2170	2170	2170	4.2	
100	100	100	100	100	100	100	4.3	
3250	3250	3250	3250	3250	3250	3250	4.4	
3904	3904	3904	3904	3904	3904	3904	4.5	
2160	2160	2160	2160	2160	2160	2160	4.7	
1061	1061	1061	1061	1061	1061	1061	4.8	
365	365	365	365	365	365	365	4.12	
3486	3486	3559	3559	3559	3559	3559	4.19	
2486	2486	2559	2559	2559	2559	2559	4.20	
1157 / 1601	1157 / 1601	1157 / 1601	1157 / 1601	1157 / 1601	1157 / 1601	1157 / 1601	4.21	
40 X 100 X 1000	40 X 100 X 1000	40 X 100 X 1000	40 X 100 X 1000	40 X 100 X 1000	40 X 100 X 1000	40 X 100 X 1000	4.22	
II A	II A	II A	II A	II A	II A	II A	4.23	
1067	1067	1067	1067	1067	1067	1067	4.24	
107	107	107	107	107	107	107	4.31	
160	160	160	160	160	160	160	4.32	
3919	3919	3986	3986	3986	3986	3986	4.33	
4056	4056	4123	4123	4123	4123	4123	4.34	
2149	2149	2216	2216	2216	2216	2216	4.35	
50	50	50	50	50	50	50	4.36	
17.5 / 18.7	18.7 / 19.6	17.1 / 18.0	17.1 / 18.0	17.1 / 18.0	17.5 / 18.7	18.7 / 19.6	5.1	
0.60 / 0.61	0.60 / 0.61	0.54 / 0.57	0.56 / 0.57	0.56 / 0.57	0.60 / 0.61	0.60 / 0.61	5.2	
0.50 / 0.42	0.50 / 0.42	0.50 / 0.42	0.50 / 0.42	0.50 / 0.42	0.50 / 0.42	0.50 / 0.42	5.3	
23211 / 12082	21805 / 11450	16020 / 11450	19082 / 11450	19082 / 11450	22028 / 11450	21805 / 11450	5.5	
19647 / 12082	21805 / 11450	13848 / 11450	16857 / 11450	16857 / 11450	19033 / 11450	21805 / 11450		
13300 / 14200	16500 / 12500	8450 / 8900	10700 / 11100	10700 / 11100	12900 / 13300	15800 / 16500		
37.0 / 34.2	41.0 / 34.2	21.7 / 29.3	26.7 / 29.3	26.7 / 29.3	28.0 / 29.3	35.4 / 29.3	5.7	
24.0 / 34.2	30.0 / 34.2	13.0 / 22.0	16.0 / 29.0	16.0 / 29.0	21.0 / 29.3	25.0 / 29.3		
Hydraulic	Hydraulic	Hydraulic	Hydraulic	Hydraulic	Hydraulic	Hydraulic	5.10	
GM 2.4L	GM 2.4L	Mazda FE	Mazda F2	Mazda F2	GM 2.4L	GM 2.4L	7.1	
46.2	46.2	32.8	38.0	38.0	46.2	46.2	7.2	
2700	2700	2700	2700	2700	2700	2700	7.3	
4 / 2400	4 / 2400	4 / 1998	4 / 2184	4 / 2184	4 / 2400	4 / 2400	7.4	
Hydrodynamic	Hydrodynamic	Hydrodynamic	Hydrodynamic	Hydrodynamic	Hydrodynamic	Hydrodynamic	8.1	
0 - 155	0 - 155	0 - 155	0 - 155	0 - 155	0 - 155	0 - 155	8.2	
66	66	62	62	62	66	66	8.3	
80	80	80	80	80	80	80	8.4	
105	105	103	103	103	105	105		
Pin	Pin	Pin	Pin	Pin	Pin	Pin	8.5	

Specification sheet truck based on:
 GLP 30 VX and GLP 35 VX 3105mm tof 2 stage LFL mast with
 standard carriage,1000mm forks and e-hydraulics.

VDI 2198 – General Specifications, LPG Powered GLP30VX, GLP35VX

		Yale				
		GLP 30 VX				
Characteristics	1.1	Manufacturer				
	1.2	Model designation				
		Power Train - Engine Transmission		Mazda 2.0L Standard Electronic	Mazda 2.2L Standard Electronic	Mazda 2.2L Techtronix 100
		Model - Manufacturer Designation		Base	Base	Value
	1.3	Drive: Diesel, LPG		LPG	LPG	LPG
	1.4	Operation: Seated rider		Seated Rider	Seated Rider	Seated Rider
	1.5	Load capacity	Q (kg)	3000	3000	3000
	1.6	Load centre	c (mm)	500	500	500
	1.8	Load distance	x (mm)	478	478	478
1.9	Wheelbase	y (mm)	1623	1623	1623	
Weights	2.1	Unladen weight	kg	4505	4505	4505
	2.2	Axle loading laden, front/rear	kg	6725 / 781	6725 / 781	6725 / 781
	2.3	Axle loading unladen, front/rear	kg	1907 / 2598	1907 / 2598	1907 / 2598
Wheels & Tyres	3.1	Tyres: P=pneumatic, C=cushion, SC=supercushion		SC	SC	SC
	3.2	Tyre size-front		28 X 9 - 15	28 X 9 - 15	28 X 9 - 15
	3.3	Tyre size-rear		6.50 X 10	6.50 X 10	6.50 X 10
	3.5	Number of wheels, front/rear (X = driven)		2x / 2	2x / 2	2x / 2
	3.6	Track width, front	b10 (mm)	965	965	965
	3.7	Track width, rear	b11 (mm)	967	967	967
	Dimensions	4.1	Mast tilt, forward α /back β	degrees	6 / 5	6 / 5
4.2		Height of mast, lowered	h1 (mm)	2195	2195	2195
4.3		Free lift ▲	h2 (mm)	100	100	100
4.4		Lift height ▲	h3 (mm)	3055	3055	3055
4.5		Height of mast, extended †	h4 (mm)	3809	3809	3809
4.7		Height to top of overhead guard ○	h6 (mm)	2185	2185	2185
4.8		Seat height ✕	h7 (mm)	1086	1086	1086
4.12		Towing coupling height	h10 (mm)	390	390	390
4.19		Overall length	l1 (mm)	3633	3633	3633
4.20		Length to face of forks	l2 (mm)	2633	2633	2633
4.21		Overall width, Std/Dual	b1/b2 (mm)	1186 / 1601	1186 / 1601	1186 / 1601
4.22		Fork dimensions	s/e/l (mm)	50 X 125 X 1000	50 X 125 X 1000	50 X 125 X 1000
4.23		Fork carriage to DIN 15173. Class, A/B		III A	III A	III A
4.24		Fork carriage width ▶	b3 (mm)	1067	1067	1067
4.31		Ground clearance under mast, laden	m1 (mm)	132	132	132
4.32		Ground clearance at centre of wheelbase	m2 (mm)	185	185	185
4.33		Aisle width with pallets 1000 long x 1200 wide,	Ast (mm)	4063	4063	4063
4.34		Aisle width with pallets 800 wide x 1200 long,	Ast (mm)	4196	4196	4196
4.35		Outer turning radius	Wa (mm)	2277	2277	2277
4.36	Inner turning radius	b13 (mm)	25	25	25	
Performance	5.1	Travel speed laden/unladen	km/h	18.0 / 19.1	18.0 / 19.1	18.0 / 19.1
	5.2	Lifting speed laden/unladen	m/sec	0.45 / 0.50	0.49 / 0.50	0.49 / 0.50
	5.3	Lowering speed laden/unladen	m/sec	0.50 / 0.42	0.50 / 0.42	0.50 / 0.42
	5.5	Maximum drawbar pull laden/unladen,	N	15851 / 11708	18913 / 11708	18913 / 11708
		Drawbar pull laden/unladen, @ 1.6km/h	N	12950 / 11708	16274 / 11708	16274 / 11708
		Drawbar pull laden/unladen, @ 4.8km/h	N	8100 / 8500	10500 / 11100	10500 / 11100
	5.7	Gradeability laden/unladen, @ 1.6km/h	%	17.6 / 26.6	21.5 / 26.6	21.5 / 26.6
		Gradeability laden/unladen, @ 4.8km/h	%	11.0 / 19.0	14.0 / 25.0	14.0 / 25.0
	5.10	Service brake		Hydraulic	Hydraulic	Hydraulic
	Motor	7.1	Engine manufacturer/type		Mazda FE	Mazda F2
7.2		Engine output, in accordance with ISO1585	kW	32.8	38.0	38.0
7.3		Governed speed	rpm	2700	2700	2700
7.4		Number of cylinders/displacement	cm3	4 / 1998	4 / 2184	4 / 2184
Other	8.1	Drive control		Hydrodynamic	Hydrodynamic	Hydrodynamic
	8.2	Working pressure for attachments	bar	0 - 155	0 - 155	0 - 155
	8.3	Oil flow for attachments †	l/min	62	62	62
	8.4	Average noise level at operator's ear ★	dB(A)	80	80	80
		Guaranteed sound power 2001/14/EC		103	103	103
8.5	Towing coupling type		Pin	Pin	Pin	

★ Measured according to the test cycles and based on the weighting values contained in EN12053.

† Variable

▲ Top of forks

✕ Full suspension seat in depressed position

▶ Add 32mm with load backrest

○ h6 subject to +/- 5mm tolerance

† Without load backrest

Specification sheet truck based on:

GLP 20 VX and GLP 25 VX 3290mm tof 2 stage LFL mast with standard carriage, 1000mm forks and e-hydraulics.

		Yale				1.1	Characteristics
		GLP 35 VX				1.2	
GM 2.4L Techtronix 100	GM 2.4L Techtronix 200X	Mazda 2.2L Standard Electronic	Mazda 2.2L Techtronix 100	GM 2.4L Techtronix 100	GM 2.4L Techtronix 200X		
Productivity	Productivity	Base	Value	Productivity	Productivity		
LPG	LPG	LPG	LPG	LPG	LPG	1.3	
Seated Rider	Seated Rider	Seated Rider	Seated Rider	Seated Rider	Seated Rider	1.4	
3000	3000	3500	3500	3500	3500	1.5	
500	500	500	500	500	500	1.6	
478	478	478	478	478	478	1.8	
1623	1623	1700	1700	1700	1700	1.9	
4505	4505	4816	4816	4816	4816	2.1	
6725 / 781	6725 / 781	7392 / 925	7392 / 925	7392 / 925	7392 / 925	2.2	
1907 / 2598	1907 / 2598	1868 / 2948	1868 / 2948	1868 / 2948	1868 / 2948	2.3	
SC	SC	SC	SC	SC	SC	3.1	
28 X 9 - 15	28 X 9 - 15	28 X 9 - 15	28 X 9 - 15	28 X 9 - 15	28 X 9 - 15	3.2	
6.50 X 10	6.50 X 10	6.50 X 10	6.50 X 10	6.50 X 10	6.50 X 10	3.3	
2x / 2	2x / 2	2x / 2	2x / 2	2x / 2	2x / 2	3.5	
965	965	965	965	965	965	3.6	
967	967	967	967	967	967	3.7	
6 / 5	6 / 5	6 / 5	6 / 5	6 / 5	6 / 5	4.1	
2195	2195	2195	2195	2195	2195	4.2	
100	100	100	100	150	150	4.3	
3055	3055	3055	3055	100	100	4.4	
3809	3809	3809	3809	3055	3055	4.5	
2185	2185	2185	2185	2185	2185	4.7	
1086	1086	1086	1086	1086	1086	4.8	
390	390	390	390	390	390	4.12	
3633	3633	3734	3734	3734	3734	4.19	
2633	2633	2734	2734	2734	2734	4.20	
1186 / 1601	1186 / 1601	1186 / 1601	1186 / 1601	1186 / 1601	1186 / 1601	4.21	
50 X 125 X 1000	50 X 125 X 1000	50 X 125 X 1000	50 X 125 X 1000	50 X 125 X 1000	50 X 125 X 1000	4.22	
III A	III A	III A	III A	III A	III A	4.23	
1067	1067	1067	1067	1067	1067	4.24	
132	132	132	132	132	132	4.31	
185	185	185	185	185	185	4.32	
4063	4063	4156	4156	4156	4156	4.33	
4196	4196	4293	4293	4293	4293	4.34	
2277	2277	2380	2380	2380	2380	4.35	
25	25	54	54	54	54	4.36	
18.7 / 19.8	19.8 / 20.9	18.0/19.1	18.0 / 19.1	18.7 / 19.8	19.8 / 20.9	5.1	
0.53 / 0.54	0.53 / 0.54	0.49 / 0.50	0.49 / 0.50	0.53 / 0.54	0.53 / 0.54	5.2	
0.50 / 0.42	0.50 / 0.42	0.50 / 0.42	0.50 / 0.42	0.50 / 0.42	0.50 / 0.42	5.3	
21952 / 11708	21805 / 11708	18913 / 12594	18913 / 12594	21609 / 12594	21805 / 12594	5.5	
18877 / 11708	21805 / 11708	15735 / 12594	15735 / 12594	18570 / 12594	21805 / 12594		
13400 / 11700	15600 / 16000	10500 / 11100	10500 / 11100	12500 / 13300	16000 / 16900		
25.8 / 26.6	30.4 / 26.6	19.4 / 26.9	19.4 / 26.9	21.7 / 26.9	27.3 / 26.9	5.7	
18.1 / 26.6	22.1 / 26.6	13.5 / 23.0	13.5 / 23.0	15.2 / 26.9	20.0 / 26.9		
Hydraulic	Hydraulic	Hydraulic	Hydraulic	Hydraulic	Hydraulic	5.10	
GM 2.4L	GM 2.4L	Mazda F2	Mazda F2	GM 2.4L	GM 2.4L	7.1	
46.2	46.2	38.0	38.0	46.2	46.2	7.2	
2700	2700	2700	2700	2700	2700	7.3	
4 / 2400	4 / 2400	4 / 2184	4 / 2184	4 / 2400	4 / 2400	7.4	
Hydrodynamic	Hydrodynamic	Hydrodynamic	Hydrodynamic	Hydrodynamic	Hydrodynamic	8.1	
0 - 155	0 - 155	0 - 155	0 - 155	0 - 155	0 - 155	8.2	
66	66	62	62	66	66	8.3	
80	80	80	80	80	80	8.4	
105	105	103	103	105	105		
Pin	Pin	Pin	Pin	Pin	Pin	8.5	

Specification sheet truck based on:
GLP 30 VX and GLP 35 VX 3105mm tof 2 stage LFL mast with
standard carriage, 1000mm forks and e-hydraulics.

VX Series

Models: GDP/GLP 20VX, 25VX, 30VX, 35VX

Yale Veracitor VX Series

This series of trucks is available in three configurations.

The Veracitor Base truck offers first-rate performance for standard-duty applications, geared to minimise cost of acquisition without compromising performance.

The Veracitor Value truck provides excellent performance for standard and medium-duty applications, optimised for lowest hourly operation cost.

The Veracitor Productivity truck delivers maximum performance for medium to heavy-duty applications with state-of-the-art features and industry leading power.

Engines

Engines feature a rigid cast iron block and main bearing caps.

Hydraulic valve lifters eliminate the need for manual adjustment. All engines include hardened exhaust valve seats, the GM engine's valves are stellite coated for superior durability. All engines are Tier 2 emissions compliant featuring closed loop emissions regulation systems that continually monitor exhaust and adjust fuel/air mix. The GM engine also features an electronic throttle for precise performance and control.

Fuel System

The Mazda LPG engine uses a single barrel non adjustable carburetor with an LPG injector and a regulator/vaporizer. The Engine Control Unit controls the LPG injector fueling.

The GM LPG use sequential port fuel injection, vaporiser/ regulator to convert fuel from a liquid to a gas for vapor injection. The Engine Control Unit (ECU) electronically controls the fuel/air mix, and spark advance to provide the necessary torque. The ECU inputs include manifold air pressure temperature, engine coolant temperature, accelerator pedal position, throttle position, engine speed, cam signal, and oxygen sensor signal.

The Yanmar fuel system has an Electro-mechanical controlled throttle providing excellent response time. Super quick glow plugs allow the engine to start quickly and reliably under cold conditions, the cold start device delivering a cleaner exhaust by advancing the fuel injection timing based on water temperature. Emissions have been reduced by controlling fuel injection timing according to engine load.

Transmission

Four transmission selections are available with multiple engine configurations for a wide variety of material handling applications.

1) Standard Electronic features electronic inching, electric shift control, neutral start switch, anti-restart protection and heavy duty clutch packs.

A single pedal controls both inching and braking, optional dual inch/brake pedals are available if preferred. A 100 mesh suction and a 10 micron return line filtration protect the transmission from abrasive contaminants.

2) The Techtronix 100 has all the Standard Electronic features plus Auto Deceleration System through the controlled application of clutch packs, reduces tyre spin by precisely regulating engine speed during controlled power reversals.

3) The Techtronix 200 has all the Techtronix 100 features, plus Two Speed Auto Shift (2 x forward, 1 x reverse).

Cooling System

The cooling system employs a 43cm blade pusher-type fan. A permanently lubricated water pump and a high capacity, cross-flow radiator ensure rapid heat dissipation. The sealed cooling system operates at 15psi, the coolant recovery tank allows visual inspection of coolant level. A transmission oil cooler is integrated into the radiator, located in the side tank. The optional combicooler radiator features an externally mounted transmission oil cooler for increased heat transfer capability. All radiators are soft mounted for durability.

Drive Axle

The drive axle is designed to withstand heavy-duty applications and absorb shock loads. It is a "self contained" assembly isolated from the transmission by a heavy-duty rubber isolator. The axle shafts utilize a "rolled fillet" root spline design for increased resistance to torsion stress. A magnetic sump plug collects any metal particles circulating in the axle oil to prevent component wear.

Brakes

Brakes are duo-servo hydraulic, self-energizing, and automatic adjusting drum brake assemblies. Asbestos-free brake linings are bonded to steel shoes operating in cast iron drums on the Base and Value models. The Productivity models have oil immersed brakes as standard. The single circuit master cylinder has sealed fluid reservoir and features a fluid level sensor which activates an indicator light on the instrument panel.

Hydraulic Power Steering

Hydrostatic steering provides responsive control and eliminates mechanical linkages for reduced surface shock and

simplified maintenance. The steering wheel is 30cm in diameter with a textured surface grip and spinner knob, and requires only four turns lock-to-lock. The centre mounted steer cylinder is located within the confines of the steer axle for protection.

Steer Axle

Constructed from cast steel, the steer axle is rubber shock mounted to the frame for reduced wear and vibration. The CSE (Continuous Stability Enhancement) system enhances lateral truck stability through reduced steer axle articulation, while simultaneously allowing uncompromised uneven surface travel.

Operator's Compartment

Base truck features cowl mounted hydraulic control levers positioned on the right side of the steering column.

Value and Productivity trucks feature Accutouch or PalmTech electrohydraulic controls integrated into the operator's right-side armrest for superior ergonomic actuation.

Automotive-style pedal arrangement with a large, single inch/brake pedal is standard.

Intellix Vehicle System Management (VSM)

VSM acts as a master truck controller, providing extensive monitoring and control of truck functions and systems.

CANbus technology reduces wiring complexity and enables communications between truck systems. The dash display transmits continual feedback to the operator and allows communication of service codes. On-board diagnostics enable quick and easy troubleshooting. The electrical system features sealed connectors and Hall Effect sensors for superior dependability.

Hydraulic System

Hydraulic system incorporates a gear type pump with cast iron body for quiet efficiency. The system is protected from overloads by a main relief valve for the lift circuit and secondary relief valve for tilt and auxiliary functions. Oil is double filtered through a 100 mesh suction line strainer and 10 micron return line filter. Hydraulic tank is integrated into the frame.

For Accutouch or PalmTech joystick electrohydraulic controls, an emergency lowering valve is provided to allow the load to be lowered in the event of power loss. O-ring face seal fittings are used in all high pressure hydraulic connections.



NACCO Materials Handling Limited trading as Yale Europe Materials Handling
Flagship House, Reading Road North, Fleet, Hampshire GU51 4WD, United Kingdom.
Tel: + 44 (0) 1252 770700 Fax: + 44 (0) 1252 770784
www.yale-europe.com

Country of Registration: England. Company Registration Number: 02636775



Safety. This truck conforms to the current EU requirements. Specification is subject to change without notice.

Publication part no. 290000120 Rev.15
Printed in The United Kingdom (050910HG) EN

Yale is a registered trade mark.
© Yale Europe Materials Handling 2008. All rights reserved.

Truck shown with optional equipment