

# Electric Forklift Truck

Capacities 1,000kg, 1,250kg and 1,500kg

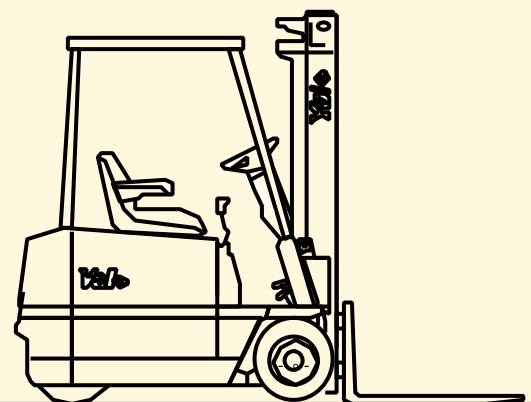

- Available with Supercushion tyres
- Auto regenerative braking increases battery, brake and brush life
- Optimum operator comfort
- Compact and manoeuvrable

## Truck Dimensions

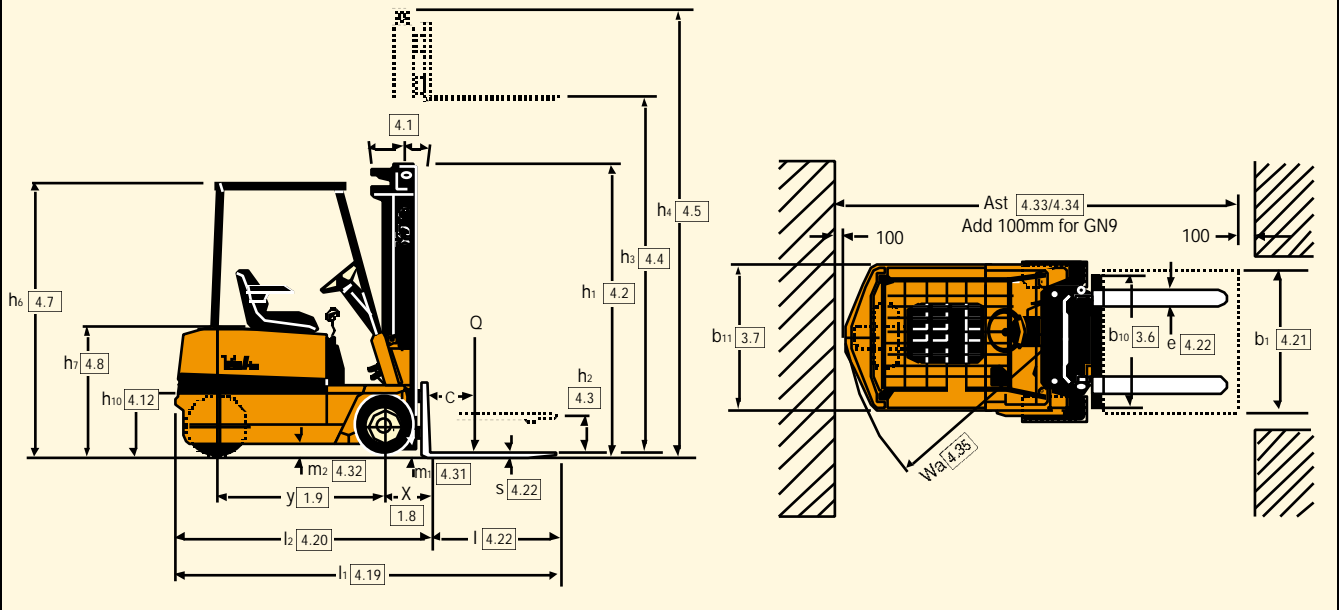

## Mast details and capacity ratings (kg) - Supercushion tyres

Model		ERP 10 RCF						ERP 12 RCF						ERP 15 RCF										
Tyres		18x7 - 8						18x7 - 8						18x7 - 8										
Width across tyres		2stg - 1046mm / 3stg - 1180mm						2stg - 1046mm / 3stg - 1180mm						2stg - 1046mm / 3stg - 1180mm										
Mast	OAH	FFH	MFH	h4	Tilt		Forks			Integral Sideshift			Forks			Integral Sideshift			Forks			Integral Sideshift		
					F	B	500	600	700	500	600	700	500	600	700	500	600	700	500	600	700	500	600	700
	h1	h2+s	h3+s				LC	LC	LC	LC	LC	LC	LC	LC	LC	LC	LC	LC	LC	LC	LC	LC		
2-stg LFL (V)	2092	90	3300	3801	3	6	1000	920	830	960	860	780	1250	1140	1030	1200	1080	970	1500	1370	1240	1440	1290	1170
	2342	90	3800	4301	3	6	1000	910	820	960	860	780	1250	1140	1030	1200	1070	970	1500	1370	1230	1440	1290	1170
	2692	90	4300	4801	3	6	930	850	770	890	800	720	1180	1070	960	1120	1010	910	1420	1290	1160	1360	1220	1100
2-stg FFL (F)	1942	1384	3000	3501	3	6	1000	920	830	960	860	780	1250	1140	1030	1200	1080	970	1500	1370	1230	1440	1290	1170
	2092	1524	3300	3801	3	6	1000	920	830	960	860	780	1250	1140	1030	1200	1070	970	1500	1370	1230	1440	1290	1170
3-stg FFL (E)	1942	1374	4420	4921	3	6	1000	910	820	960	860	770	1250	1140	1030	1200	1070	970	1480	1350	1240	1400	1290	1180
	2092	1524	4870	5371	3	6	930	850	770	890	800	720	1170	1070	960	1120	1010	910	1410	1300	1180	1340	1230	1110
	2342	1774	5320	5821	3	6	860	780	710	820	730	660	1090	990	890	1040	930	840	1340	1220	1100	1290	1150	1040
	2667	2099	5995	6496	3	4	750	670	610	710	630	570	960	870	780	910	820	740	1200	1090	980	1150	1030	930

Alternative capacities available with pneumatic or cushion tyres. Contact your lift truck dealer.

Integral sideshift is 906.2 wide or 939 with load backrest.

## VDI 2198 - General Specifications

		Yale		Yale		Yale			
Characteristics	1.1	Manufacturer	Yale		Yale		Yale		
	1.2	Model designation	ERP10RCF		ERP12 RCF		ERP15RCF		
	1.3	Drive: Electric	Battery		Battery		Battery		
	1.4	Operation	Seated		Seated		Seated		
	1.5	Load capacity	Q (kg)	1000	1250	1500			
	1.6	Load centre	c (mm)	500	500	500			
	1.8	Load distance	x (mm)	318	318	318			
	1.9	Wheelbase *	y (mm)	1130 / 1163 / 1229		1130 / 1163 / 1229		1130 / 1163 / 1229	
	Weights	2.1	Unladen weight (max. battery)	kg	2783		2955		3163
2.2		Axle loading laden, front/rear (max. battery) ☞	kg	3095	685	3513	694	3980	687
2.3		Axle loading unladen, front/rear (max. battery) ☞	kg	1396	1387	1381	1574	1419	1744
Wheels & Tyres	3.1	Tyres: P=pneumatic, C=cushion, SC=supercushion	SC		SC		SC		
	3.2	Tyre size - front	18x7-8		18x7-8		18x7-8		
	3.3	Tyre size - rear	18x7-8		18x7-8		18x7-8		
	3.5	Number of wheels, front/rear (X = driven)	2/1X		2/1X		2/1X		
	3.6	Track width, front ↗	b10 (mm)	865		865		865	
	3.7	Track width, rear	b11 (mm)	-		-		-	
	Dimensions	4.1	Mast tilt, forward / back	Degrees	3	6	3	6	3
4.2		Height of mast, lowered	h1 (mm)	2091.5		2091.5		2091.5	
4.3		Free lift ▲	h2 (mm)	50		50		50	
4.4		Lift height ▲	h3 (mm)	3260		3260		3260	
4.5		Height of mast, extended +	h4 (mm)	3801		3801		3801	
4.7		Height to top of overhead guard ○	h6 (mm)	1972		1972		1972	
4.8		Seat height ✕	h7 (mm)	925.5		925.5		925.5	
4.12		Towing coupling height	h10 (mm)	471.5		471.5		471.5	
4.19		Overall length ☞	l1 (mm)	2770		2770		2770	
4.20		Length to front face of forks ☞	l2 (mm)	1770		1770		1770	
4.21		Overall width ↗	b1 (mm)	1050		1050		1050	
4.22		Fork dimensions	s/e/l (mm)	40 x 80 x 1000		40 x 80 x 1000		40 x 80 x 1000	
4.23		Fork carriage DIN 15173. Class, A/B		IIA		IIA		IIA	
4.24		Fork carriage width ▶	b3 (mm)	857		857		857	
4.31		Ground clearance under mast, laden	m1 (mm)	88		88		88	
4.32		Ground clearance at centre of wheelbase	m2 (mm)	110.5		110.5		110.5	
4.33		Aisle width with pallets 1000 long x 1200 wide ↗	Ast (mm)	3098		3098		3098	
4.34		Aisle width for pallets 800 wide x 1200 long *	Ast (mm)	3219.8		3219.8		3219.8	
4.35	Outer turning radius	Wa (mm)	1450		1450		1450		
4.36	Inner turning radius	b13 (mm)	0		0		0		
Performance	5.1	Travel speed laden/unladen	km/h	10	11	10	11	9	11
	5.2	Lifting speed laden/unladen	m/sec	0.28	0.43	0.26	0.43	0.24	0.43
	5.3	Lowering speed laden/unladen	m/sec	0.55	0.51	0.55	0.51	0.55	0.51
	5.5	Drawbar pull laden/unladen, 60 minute rating	N	920	1100	820	1060	690	990
	5.6	Max. drawbar pull laden/unladen, 5 minute rating	N	4230	5600	4230	5550	4390	5500
	5.7	Gradeability laden/unladen, 30 minute rating	%	5	8	4	7	4	6
	5.8	Max. gradeability, laden/unladen, 5 minute rating	%	12	15	11	15	10	15
	5.9	Acceleration time laden/unladen	sec	6	6	6	6	7	6
	5.10	Service brake		Hydraulic		Hydraulic		Hydraulic	
	Motor	6.1	Drive motor output (S2 60 minute rating)	kW	4.2		4.2		4.2
6.2		Lifting motor, (S3 15% rating)	kW	4.8		4.8		4.8	
6.3		Battery to DIN 43531/35/36 A, B, C, no		DIN 43535A		DIN 43535A		DIN 43535A	
6.4		Battery voltage/capacity at 5hr rate >=	V/ah	24	880	24	880	24	880
6.5		Battery weight (min/max)	kg	450	730	450	730	620	800
6.6		Power consumption in accordance with VDI cycle	kWh/h						
Other	8.1	Drive control		SEM electronic		SEM electronic		SEM electronic	
	8.2	Working pressure for attachments	bar	155		155		155	
	8.3	Oil flow for attachments ↓	l/min	20		20		20	
	8.4	Average noise level at operator's ear ★	dB (A)	67		67		67	
	8.5	Towing coupling type		Pin		Pin		Pin	

★ L<sub>pa</sub>, measured according to the test cycles and based on the weighting values contained in EN12053

◆ Semi-suspension (FS1100) specified

▶ Add 32mm with load backrest

☞ With mast vertical

↗ Add 134mm for 3 stage mast

↗ Add 130mm for 3 stage mast

↗ 2 stage and FFL mast, add 20mm for 3 stage mast

\* 2 stage and FFL mast, add 19mm for 3 stage mast

>= 1000Ah non-DIN also available

▲ Top of forks

✕ Subtract 22 mm for suspension seat

+ Without load backrest

○ h6 subject to +/- 5 mm tolerance

↓ Variable

Spec sheet truck based on :-  
3300mm top of forks 2 stage LFL mast with standard carriage and 1000mm forks with LBR. DIN battery configuration.

## Models:

10RCF, 12RCF, 15RCF

### Motors

High class insulation traction and hoist motors are suitable for the most arduous applications. High power separately excited drive motor (SEM) has independently regulated armature and field currents for optimum traction control and performance with high energy efficiency and low power consumption.

### Drive Control

MOSFET controller provides smooth infinitely variable speed control and precise inching for close manoeuvring. High frequency, noiseless operation. Power contactors are eliminated. Controlled electrical braking by progressive release of the accelerator pedal eliminates the need for normal service brake operation.

Direction control return to neutral feature prevents uncontrolled truck movement at start up.

The controller is housed in the counterweight compartment for maximum protection and ease of access.

### Steering

Low noise, low power consumption hydrostatic power steering via hydraulic motor drive. The steer column has adjustable rake with 5 positive lockable positions.

### Hydraulic System

Large capacity steel tank includes a full flow return line filter. The control valve includes dual pressure relief valves to protect lift and auxiliary circuits from overload and anti cavitation to prevent voids in the tilt cylinders and improve tilt control.

### Mast

A full range of Yale Hi-Vis™ 2 stage LFL and 2 and 3 stage FFL masts are available. Yale Hi-Vis™ masts are designed for maximum visibility, with widely spaced channels, lift chains and main lift cylinders.

### Transmission

Rear wheel drive through vertically mounted gearbox, which also acts as the steer axle. Steer wheel and tyre can be removed without disturbing the wheel bearings.

### Brakes

Heavy duty, asbestos free and self-energising, independent service and parking brakes act upon the front wheels. Service brake is actuated by large width pedal. Parking brake is applied by lever mounted on left-hand side of the front cowl through an independent mechanical linkage.

### Chassis and Battery Compartment

A robust welded steel structure protects truck components. The battery is located in the chassis, restrained by a mechanical latch.

### Operator Compartment, Controls and Instrumentation.

The RCF is designed for optimum operator comfort with spacious operator compartment, easy to handle control levers and adjustable seat.

An ergonomically positioned handgrip eases entry and exit from the truck.

In addition, MOSFET drive control and the exceptionally low noise level (67dB(A) sound pressure at operator's ear) provide a comfortable ride.

### Options

- Foot Directional Control
- Reverse Alarm
- Integrated sideshift



Yale Europe Materials Handling  
Flagship House, Reading Road North,  
Fleet, Hampshire GU51 4WD, United Kingdom.  
Tel: + 44 (0) 1252 770700 Fax: + 44 (0) 1252 770784  
www.yale-europe.com



**Safety.** This truck conforms to the current EU requirements.  
Specification is subject to change without notice

Publication part no. 258725491 Rev.04-05  
Printed in The United Kingdom (0707??/????HG) EN

Yale is a registered trade mark.  
© Yale Europe Materials Handling 2007. All rights reserved.

Truck shown with optional equipment