

Tiller arm stacker truck with
folding platform and side arms
Capacities 1250kg, 1500kg

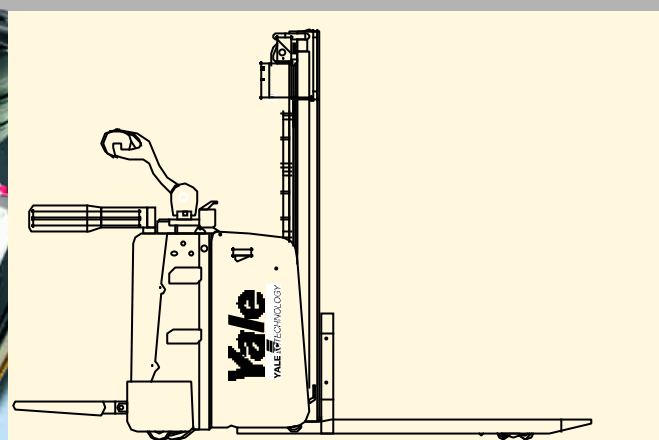

- Large operator platform
- COMBI-MOSFET Controller
- Yale AC Technology™
- Brushless power steering motor
- High manoeuvrability
- Dual purpose machine for pedestrian or ride on operation
- Initial lift option

Truck Dimensions MS12-15X

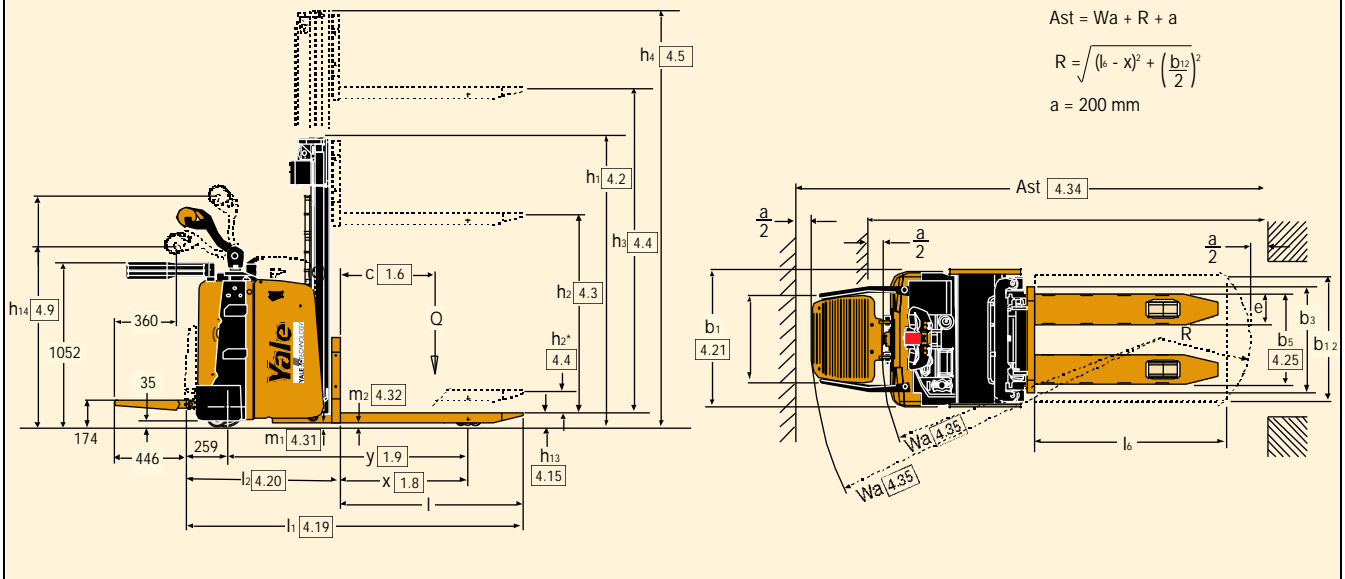

Tiller Head

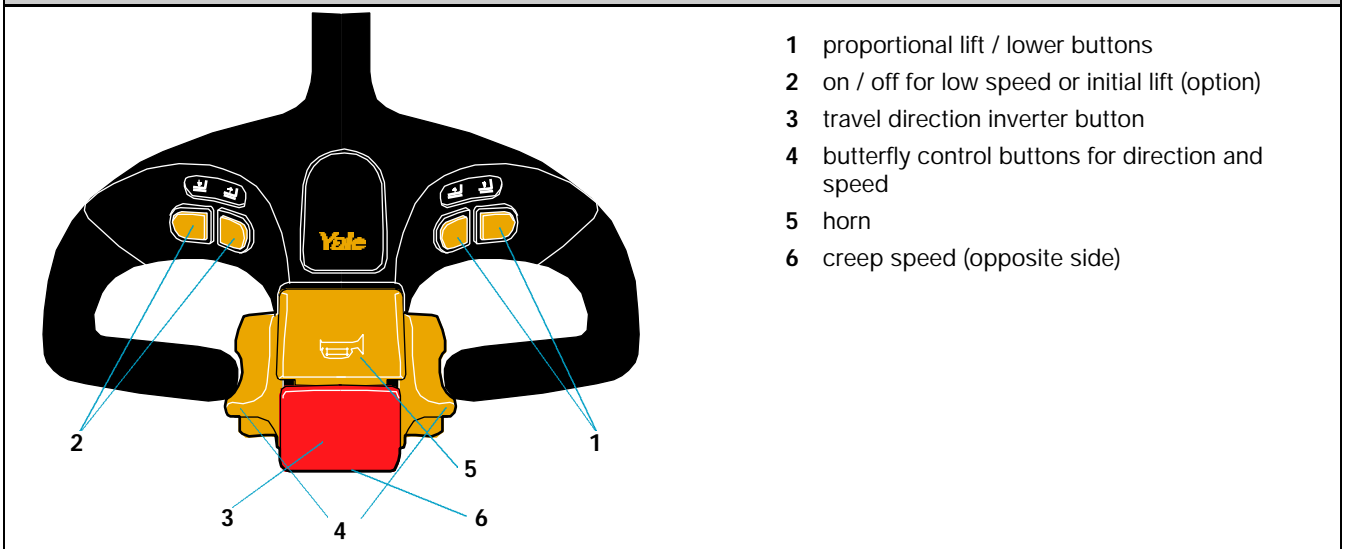

Mast details - MS12X, MS15X

Mast type	Lift stroke h_3 mm	Maximum fork height $h_3 + h_{13}$ mm	Free lift stroke h_2^{***} mm	Height of mast lowered h_1^{***} mm	Height of mast extended h_4^{**} mm	
Type 'J' profile	2-stage LFL*	2768	2858	100	1877*	3330
		2968	3058	100	1977*	3530
		3168	3258	100	2077*	3730
		3368	3458	100	2177*	3930
		3768	3858	100	2377*	4330
	2-stage FFL	4168	4258	100	2577*	4730
		2604	2694	1260	1827	3166
		2804	2894	1360	1927	3366
		3004	3094	1460	2027	3566
		3204	3294	1560	2127	3766
3404		3494	1660	2227	3966	
3-stage FFL	3604	3694	1760	2327	4166	
	4004	4094	1960	2527	4566	
	4028	4118	1260	1827	4590	
	4328	4418	1360	1927	4890	
	4628	4718	1460	2027	5190	

* h_1 with 100 mm free lift
 ** h_4 with load backrest add 528 mm
 *** with IL lifted add 130 mm

VDI 2198 - General Specifications

		Yale	Yale	Yale	Yale	
Characteristics	1.1 Manufacturer		Yale	Yale	Yale	
	1.2 Model designation		MS12X⁽¹⁾	MS15X⁽²⁾	MS12X-IL⁽¹⁾	MS15X - IL⁽²⁾
	1.3 Power: battery, diesel, LPG, electric mains		Battery	Battery	Battery	Battery
	1.4 Operation: manual, pedestrian, stand, seat		Pedestrian / (Stand-on)	Pedestrian / (Stand-on)	Pedestrian / (Stand-on)	Pedestrian / (Stand-on)
	1.5 Load capacity	Q (t)	1.25	1.5	1.25	1.5
	1.6 Load centre	c (mm)	600	600	600	600
	1.8 Load distance	x (mm)	713	701	811	811
	1.9 Wheel base	y (mm)	1423	1423	1520	1520
	Weights	2.1 Unladen weight	kg	1398 ⁽³⁾	1570 ⁽³⁾	1398 (3)
2.2 Axle loading laden, front/rear		kg	956 ⁽³⁾ / 1692	1142 ⁽³⁾ / 1928	956(3) / 1705	1142(3) / 1928
2.3 Axle loading unladen, front/rear		kg	926 ⁽³⁾ / 472	1012 ⁽³⁾ / 558	926(3) / 472	1012(3) / 558
Wheels and Tyres	3.1 Tyres: rubber, polyurethane, Vulkollan, front/rear		Vulkollan / Vulkollan	Vulkollan / Vulkollan	Vulkollan / Vulkollan	Vulkollan / Vulkollan
	3.2 Tyre size, front		ø 254 x 90	ø 254 x 90	ø 254 x 90	ø 254 x 90
	3.3 Tyre size, rear		ø 85 x 74	ø 85 x 74	ø 85 x 74	ø 85 x 74
	3.4 Additional Wheels (dimensions)		ø 125 x 50	ø 125 x 50	ø 125 x 50	ø 125 x 50
	3.5 Wheels number front/rear (x = driven)		1x + 1 / 4	1x + 1 / 4	1x + 1 / 4	1x + 1 / 4
	3.6 Track width, front	b 10 (mm)	564	564	564	564
	3.7 Track width, rear	b 11 (mm)	395	395	395	395
Dimensions	4.2 Height of mast, lowered	h1 (mm)	see chart	see chart	see chart	see chart
	4.3 Free lift	h2 (mm)	see chart	see chart	see chart	see chart
	4.4 Lift height	h3 (mm)	see chart	see chart	see chart	see chart
	4.5 Height of mast, extended	h4 (mm)	see chart	see chart	see chart	see chart
	4.6 Initial lift	h5 (mm)	-	-	130	130
	4.9 Height of tiller arm in working position min./max.	h14 (mm)	1220 / 1460	1220 / 1460	1220 / 1460	1220 / 1460
	4.15 Lowered height	h13 (mm)	90	90	90	90
	4.19 Overall length (pedestrian)	l1 (mm)	2129	2141	2129	2141
	4.19 Overall length (stand-on)	l1 (mm)	2575 ⁽⁴⁾	2587 ⁽⁴⁾	2575 ⁽⁴⁾	2587 ⁽⁴⁾
	4.20 Length to face of forks (pedestrian)	l2 (mm)	969	981	969	981
	4.20 Length to face of forks (stand-on)	l2 (mm)	1415 ⁽⁴⁾	1427 ⁽⁴⁾	1415 ⁽⁴⁾	1427 ⁽⁴⁾
	4.21 Overall width	b1/b2 (mm)	860	860	860	860
	4.22 Fork dimensions	s/e/l (mm)	65 / 180 / 1160	65 / 180 / 1160	55 / 195 / 1160	65 / 195 / 1160
	4.24 Fork carriage width	b3 (mm)	675	675	675	675
	4.25 Outside fork width min./max	b5 (mm)	570	570	570	570
	4.31 Ground clearance under mast, laden	m1 (mm)	30	30	30	30
	4.32 Ground clearance centre of wheelbase	m2 (mm)	20	20	30	30
	4.33 Aisle width with pallet 1000x1200 crossways VDI 2198 (Wa + R + a) (stand-on)	Ast (mm)	2994 ⁽⁷⁾	3012 ⁽⁷⁾	3055 ⁽⁷⁾	3073 ⁽⁷⁾
	Aisle width with pallet 1000x1200 crossways VDI 2198 (Wa + R + a) (Pedestrian)	Ast (mm)	2555	2573	2617	2635
	4.33 Aisle width with pallet 1000x1200 crossways VDI 3597 (stand-on)	Ast (mm)	2616 ⁽⁷⁾	2634 ⁽⁷⁾	2615 ⁽⁷⁾	2633 ⁽⁷⁾
	Aisle width with pallet 1000x1200 crossways VDI 3597 (Pedestrian)	Ast (mm)	2177	2195	2177	2195
4.34 Aisle width with pallet 800x1200 lengthwise VDI 2198 (Wa + R + a) (Stand-on)	Ast (mm)	2959 ⁽⁷⁾	2977 ⁽⁷⁾	2894 ⁽⁷⁾	2912 ⁽⁷⁾	
Aisle width with pallet 800x1200 lengthwise VDI 2198 (Wa + R + a) (Pedestrian)	Ast (mm)	2520	2538	2546	2474	
4.34 Aisle width with pallet 800x1200 lengthwise VDI 3597 (Stand-on)	Ast (mm)	2816 ⁽⁷⁾	2834 ⁽⁷⁾	2815 ⁽⁷⁾	2833 ⁽⁷⁾	
Aisle width with pallet 800x1200 lengthwise VDI 3597 (Pedestrian)	Ast (mm)	2377	2395	2377	2395	
4.35 Turning radius (stand-on)	Wa (mm)	2129 ⁽⁷⁾	2129 ⁽⁷⁾	2226 ⁽⁷⁾	2226 ⁽⁷⁾	
Turning radius (Pedestrian - tiller in vertical position, creep speed function)	Wa (mm)	1690	1690	1788	1788	
Performance	5.1 Travel speed laden/unladen (pedestrian) ⁽⁴⁾	km/h	6 / 6 ⁽⁸⁾	6 / 6	6 / 6	6 / 6
	5.1 Travel speed laden / unladen (stand-on) ⁽⁴⁾	km/h	6 / 6 ⁽⁸⁾	8 / 8.5	8 / 8.5	8 / 8.5
	5.2 Lift speed laden/unladen ⁽⁴⁾	m/s	0.16 / 0.22	0.16 / 0.22	0.16 / 0.22	0.16 / 0.22
	5.3 Lowering speed laden/unladen ⁽⁴⁾	m/s	0.3 / 0.28	0.3 / 0.28	0.3 / 0.28	0.3 / 0.28
	5.7 Gradeability laden/unladen ⁽⁵⁾	%	8 / 10	8 / 10	8 / 10	8 / 10
	5.8 Max. gradeability laden/unladen ⁽⁵⁾	%	8 / 10	8 / 10	8 / 10	8 / 10
	5.10 Service Brake		el.magnetic	el.magnetic	el.magnetic	el.magnetic
Power Unit	6.1 Drive motor, S2 60 minute rating	kW	2.2 ⁽⁶⁾	4.0	4.0	4.0
	6.2 Lift motor, S3 14 % rating	kW	3.0	3.0	3.0	3.0
	6.3 Battery according to DIN 43531/35/36 A,B,C, no		no	no	no	no
	6.4 Battery voltage/capacity at 5 hours rate	V/Ah	24 / 345	24 / 345	24 / 345	24 / 345
	6.5 Battery weight (+/- 5%)	kg	300	300	300	300
	6.6 Consumption according to VDI cycle	kWh/h	/	/	/	/
Misc.	8.1 Drive control		Mosfet - AC	Mosfet - AC	Mosfet - AC	Mosfet - AC
	8.4 Average noise level at operator's ear	dB (A)	< 70	< 70	< 70	< 70

⁽¹⁾ Values refer to truck with two stage HiVi mast, h3=2968mm

⁽²⁾ Values refer to truck with three stage FFL mast, h3=4628mm

⁽³⁾ Values refer to truck equipped with named mast, and battery as row 6.4. Add 50 Kg for fixed side protection or fixed rear protection

⁽⁴⁾ Traction, lift, and lower speeds may vary with alternative lift height

⁽⁵⁾ Values determined by wheel friction, if climbing ramps frequently (within 1h), consult your salesman

⁽⁶⁾ Add 61mm for fixed side protection, add 110mm for fixed rear protection

⁽⁷⁾ Add 75mm for fixed side protection. Add 114mm for fixed rear protection.

⁽⁸⁾ MS12X with mechanical steering, drive motor 2.2 Kw

() Value or text in parentheses refer to trucks fitted with fixed side protection or fixed rear protection

Models:

MS12X, MS12X-IL

MS15X, MS15X-IL

Tiller head and controls

The tiller head is designed for operator comfort featuring an ergonomic shaped handle with angled grips and integral hand guard. Large dimensioned, low effort butterfly buttons control direction of travel and speed as well as the electromagnetic brake. All controls are accessible without having to lift the hand from the handle. Dual lift and lower buttons are located on the tiller head and can be readily accessed for left or right hand use. The travel direction inverter button is designed for maximum angle of contact with the operator's body. When activated, the direction of travel is automatically reversed and the truck comes to a stop. The horn is located on top of the tiller head actuated by thumb or forefinger. The creep speed control allows the truck to be operated with the tiller arm in the vertical position at reduced speed for manoeuvring in tight confines. 4 preset performance settings provide different performance levels for forward and reverse travel speeds, reverse current braking, release braking, lift speed and acceleration, easily selectable to suit driver preference.

The tiller arm is spring assisted and returns automatically to the vertical position when released.

Instrumentation

The pallet truck's dashboard features a multi-function indicator displaying information on the status of the truck and alarm conditions should they occur. The most important operational information includes the battery discharge indicator, odometer and performance level. The red mushroom button can be pressed to stop the pallet truck immediately in case of emergency.

Operator Platform

The large operator platform allows the operator to find their own comfortable driving position. Foldable side arms are high relative to the level of the platform, providing the operator with maximum comfort and stability when manoeuvring. The "man on board" sensor integrated into the platform prevents truck operation with no operator present.

Optional rear access and side access fixed protection types are available and are particularly suitable for shuttle activity over medium to long distances.

The top casing has compartments for stationery and other small objects with an optional A4 reading stand.

Power-assisted steering

The electric motor completely eliminates steering effort, making the truck light and easy to steer in all working situations. The power steering reacts so quickly that there is no loss of performance compared to manual steering. Mechanical steering is standard on the MS12X model.

Frame and forks

The frame is made of electro-welded sheets, surface treated and varnished with a 2-pack epoxy paint. The overall chassis width of 860mm makes the truck suitable for manoeuvring in the narrowest aisles. Standard forks are 65mm thick, and have a low profile option of 55mm to allow the loading/unloading of non-standardised loads. The robust fork structure is made with two solid longitudinal members covered with a closing and reinforcing sheet. The IL versions ends of the forks are equipped with entry rollers to enhance the handling of bottom boarded pallets.

Initial Lift (option) and lift

The initial lift increases the distance from the ground, allowing transfer on irregular surfaces, loading levels and ramps. The lift/lower control is provided by two proportional push buttons located to the left of the tiller. The adjustable pull rods give uniform lifting and lowering movement of the forks. The loading rollers are tandem HD (Heavy Duty) with lubrication points and sealed bearings. Speed is automatically reduced with load arms raised and traction is automatically cut when the forks are raised >1.5m (h3).

Battery

The battery compartment takes a battery of up to 24V - 345 Ah capacity, which, together with the characteristics of the traction motor, allows considerable flexibility in operation. A vertical battery extraction option is available.

Rollers and wheels

All wheels are made from Vulkollan™. Tandem load wheels are standard, and tandem load wheels with twinned rollers and a fruit version are available as options. An optional suspension mounted castor enhances driveability and stability on imperfect flooring.

Electric motors

The AC 4 Kw drive motor gives instant response to forward and reverse traction inputs, providing considerable torque. The maintenance free motor (inspection intervals required every 1000 operating

hours) provides low cost long operative life. The servo-steering with brushless type DC motor with permanent magnets is maintenance free and incorporates the electronic control system. The DC compound 3kw lifting motor provides power in excess of the truck's operative requirements.

Traction – steering unit

The cast-iron gear train has helicoidal gears running immersed in an oil bath. The steering reduction is calculated to provide maximum performance in every working situation. The motor is mounted vertically for efficient ventilation and to eliminate flexing stresses to the power cables to ensure reduced downtime. The steering is effected by gears, a maintenance and regulation-free system based on higher specification models

Hydraulic unit

The silent, powerful hydraulic pump, activated by the electric motor, is of double gear type. The transparent tank facilitates checking of the hydraulic oil level. Lowering is controlled by a solenoid valve activated directly by the tiller pushbuttons.

Electronic controls

The Combi MOSFET controller manages both the AC traction engine and the DC lifting motor and reduces the need for electrical contactors. Its high energy efficiency and high motor performance allow considerable hourly usage in operation, reducing battery charging. The combined characteristics of the traction motor and the control panel enhance efficiency of release and inversion braking, without reduction of autonomy, leaving the electromagnetic brake for parking and emergencies only. Electronic parameters are easily customised by a service technician. The operator can choose between 4 pre-set performance levels.

Options

Various options are available, including;

- Cold store to -30°C
- Wide range of masts
- Fixed side protection
- Fixed rear protection
- Twin-bed trolley for battery change
- Vertical battery extraction
- Load backrest
- Dust ingress protection on drive motor
- Reverse alarm



Yale Europe Materials Handling
Flagship House, Reading Road North,
Fleet, Hampshire GU51 4WD, United Kingdom.
Tel: + 44 (0) 1252 770700 Fax: + 44 (0) 1252 770784
www.yale-europe.com



Safety. This truck conforms to the current EU requirements. Specification is subject to change without notice

Yale is a registered trade mark.
Publication part no. 29000138 Rev.01

Printed in The United Kingdom (090540HG) EN
© Yale Europe Materials Handling 2005. All rights reserved.

Truck shown with optional equipment