

Models: MC10, MC12, MC15

Tiller head and controls

The tiller head is designed for operator comfort and features an ergonomic shaped handle with angled grips and integral hand guard. A large dimensioned, low effort, butterfly button controls direction of travel and speed as well as the electromagnetic brake, all are accessible without having to remove the hand from the handle. Lift and lowering, tilt and side shift buttons located on the tiller head can be readily accessed for left or right hand use. The travel direction inverter button is designed for maximum angle of contact with the operator's body. When activated, the direction of travel is automatically reversed and the truck comes to a stop. The horn is located on top of the tiller head and is actuated by thumb or fore finger. The creep speed control allows the truck to be operated with the tiller arm in the vertical position at reduced speed for manoeuvring in tight confines. The tiller arm is spring assisted and returns automatically to the vertical position when released and can be rotated for ride driving (optional).

Instrumentation

The pallet truck's dash board features a multi-function indicator displaying information on the status of the truck and alarm conditions should they occur. Operational information includes that provided by the battery discharge indicator and odometer. The red mushroom shaped button can be activated to stop the truck immediately in case of an emergency.

Operator platform (optional use)

The large operator platform allows the operator to determine the most comfortable driving position during long travel distances, providing the operator with maximum comfort. The cushioned platform incorporates an operator presence switch (or "man on board" sensor), preventing the truck from operating without a driver present. The dash board has compartments for stationery and other small items with an optional A4 document holder.

Servo power steering

The servo power steering system reduces steering effort, making the truck easy and light to steer in all working situations. The steering reacts immediately to ensure maximum performance.

Chassis and forks

The steel welded chassis is surface treated and painted with two-component epoxy paint. The three chassis lengths available and the 939mm maximum width of the truck make it ideal for handling loads in tight spaces for example inside containers or in stocking corridors.

The FEM 2A forks are manufactured from forged steel.

Masts

A range of masts is available to match all operating needs. The none dampening masts are available in two stage LFL and three stage FFL configuration as standard.

Battery

A range of power options is available through a choice of vertically extracted batteries:-

24V - 300 Ah

24V - 400 Ah

Wheels

All wheels are manufactured from Vulkollan.

Load wheels are fitted in manner to avoid any impact with load unit.

Electric motors

The 4kW AC motor provides instant response to forward and reverse traction inputs, providing considerable torque. The maintenance free motor (inspection intervals required every 1,000 operating hours) provides low cost long operational life. The 3 kW DC lift motor provides power to match the truck's operational requirements.

Traction – steering unit

The cast-iron gear train has helical gears immersed in an oil bath. The motor is mounted vertically for efficient ventilation and to eliminate flexing

stresses to the power cables to ensure maximum uptime. The steering is actuated by gear-gear, a maintenance and regulation-free system.

Hydraulic unit

The silent, powerful hydraulic pump, activated by the electric motor, is of double gear type. The transparent tank makes the checking of the hydraulic oil level easy. All hydraulics functions are actuated by solenoid valves activated directly by the tiller push buttons. Lift and lowering are by proportional control.

Electronic controls

The Combi MOSFET controller manages both the AC traction engine and the DC lift motor eliminating the need for contactors. High energy efficiency and motor performance increases shift operation time and reduces battery charging. The combined characteristics of the traction motor and the operator control panel enhance the efficiency of the release and inversion braking, without reduction of autonomy. This leaves the electromagnetic brake for parking and emergencies. Electronic performance parameters are easily customised by a service technician. The truck performance output can easily be matched to ensure the maximum application requirements.

Options

Options available include:-

- Selection of drive wheels
- Selection of fork lengths
- Key Pad
- A4 document holder
- Cold store - 30°C
- Load backrest
- Mast selection
- Forks tilt
- Side shift



NACCO Materials Handling Limited
trading as **Yale Europe Materials Handling**
Flagship House, Reading Road North,
Fleet, Hampshire GU51 4WD, United Kingdom.
Tel: + 44 (0) 1252 770700 Fax: + 44 (0) 1252 770784
www.yale-europe.com

Country of Registration: England. Company Registration Number: 02636775



Safety. This truck conforms to the current EU requirements. Specification is subject to change without notice

Publication part no. 258985601 Rev.03
Printed in The United Kingdom (050810HG) EN

Yale is a registered trade mark.
© Yale Europe Materials Handling 2008. All rights reserved.

Truck shown with optional equipment



Pedestrian Counterbalanced Tiller Arm Stacker Truck

1,000kg 1,200kg and 1,500kg

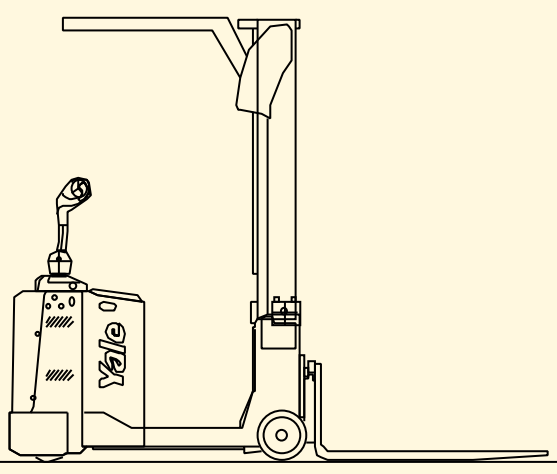

- Servo power steering
- Dual-Combi MOSFET
- Yale AC Technology
- AC drive motor
- 24V/300 - 400 Ah battery
- Rider or pedestrian operation

Truck Dimensions

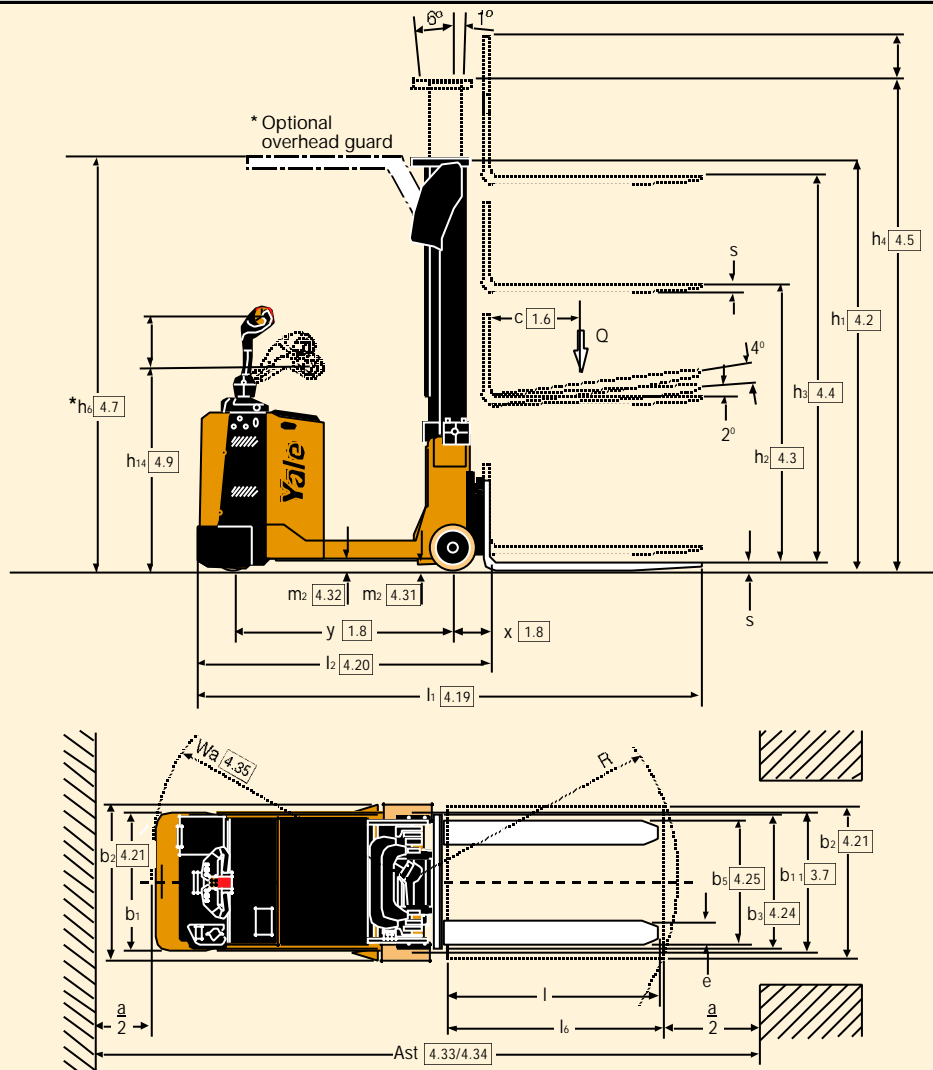

*with load backrest = + 461mm.

Tiller Head

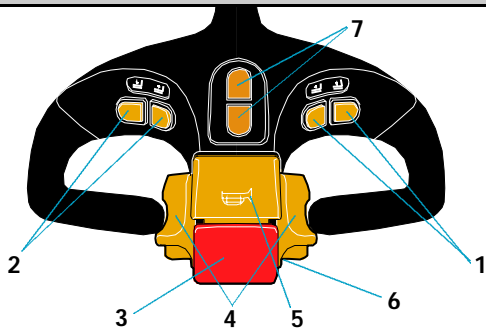

- 1 Forks lift-lowering (proportional buttons)
- 2 Side shift buttons
- 3 Travel direction inverter button
- 4 Butterfly direction and speed control buttons
- 5 Horn
- 6 Creep speed
- 7 Tilt buttons

Mast dimensions

Mast type	h_1 mm	h_2 mm	h_3 mm	h_4 mm	h_6 mm (opt.)
Two stage	2125	100	2972	3561	2312
	2325	100	3372	3961	2362
	2475	100	3672	4261	2412
	2675	100	4072	4661	2612
Three stage	2125	1555	4626	5201	2312
	2275	1705	5076	5651	2312
	2425**	1855**	5526**	6101**	2412**

** subject to application and engineering validation.

VDI 2198 - General Specifications

		Yale	Yale	Yale	Yale	Yale	
Characteristics	1.1 Manufacturer		Yale	Yale	Yale	Yale	
	1.2 Model designation		MC10	MC12	MC15	MC10	MC12
	1.3 Power		Battery	Battery	Battery	Battery	Battery
	1.4 Operation: pedestrian, stand-on, seated		Pedestrian	Pedestrian	Pedestrian	Stand on	Stand on
	1.5 Load capacity	Q (t)	1	1,2	1,5	1	1,2
	1.6 Load centre	c (mm)	500	500	500	500	500
	1.7 Load distance ⁽¹⁾	x (mm)	211	211	211	211	211
	1.8 Wheelbase	y (mm)	1300	1450	1600	1300	1450
Weights	2.1 Unladen weight	Kg	2180	2280	2230	2210	2310
	2.2 Axle loading with load, front/rear	kg	2660 / 520	2935 / 545	3345 / 385	2680 / 630	2955 / 555
	2.3 Axle loading without load, front/rear	kg	1175 / 1005	1285 / 985	1420 / 940	1195 / 1015	1315 / 995
Wheels and Tyres	3.1 Tyres: rubber, polyurethane front/rear		Vulkollan/Vulkollanø	Vulkollan/Vulkollanø	Vulkollan/Vulkollanø	Vulkollan/Vulkollanø	Vulkollan/Vulkollanø
	3.2 Tyre size, front		ø 254 x 125	254 x 125	254 x 125	254 x 125	254 x 125
	3.3 Tyre size, rear		ø 200 x 100	ø 200 x 100	ø 200 x 100	ø 200 x 100	ø 200 x 100
	3.5 Wheels, number front/rear (x = driven)		1 x /2	1 x /2	1 x /2	1 x /2	1 x /2
	3.7 Track width, rear	b11	839	839	839	839	839
Dimensions	4.1 Tilt forwards/backwards tilt	Degrees	+ 2 / - 4	+ 2 / - 4	+ 2 / - 4	+ 2 / - 4	+ 2 / - 4
	4.2 Height of mast, lowered	h1 (mm)	See Table	See Table	See Table	See Table	See Table
	4.3 Free lift	h2 (mm)	See Table	See Table	See Table	See Table	See Table
	4.4 Lift height	h3 (mm)	See Table	See Table	See Table	See Table	See Table
	4.5 Height of mast, extended	h4 (mm)	See Table	See Table	See Table	See Table	See Table
	4.7 Over head guard height **	h6 (mm)	-	-	-	See Table	See Table
	4.9 Height of tiller ⁽³⁾	h14 (mm)	1180 / 1530	1180 / 1530	1180 / 1530	1220 / 1570	1220 / 1570
	4.15 Lowered height	h13 (mm)	35	35	35	35	35
	4.19 Overall length ⁽¹⁾	l1 (mm)	2742	2892	3042	2742	2892
	4.20 Length to face of forks ⁽¹⁾	l2 (mm)	1742	1892	2042	1742	1892
	4.21 Overall width	b1/b2 (mm)	788 / 939	788 / 939	788 / 939	788 / 939	788 / 939
	4.22 Fork dimensions ⁽²⁾	s/e/l	35 / 100 / 1000	35 / 100 / 1000	35 / 100 / 1000	35 / 100 / 1000	35 / 100 / 1000
	4.23 Fork carriage DIN 15173, Class/form A,B		2 / A	2 / A	2 / A	2 / A	2 / A
	4.24 Fork carriage width	b3 (mm)	800	800	800	800	800
	4.25 Outside fork width	b5 (mm)	240 / 672	240 / 672	240 / 672	240 / 672	240 / 672
4.31 Ground clearance under mast, with load	m1(mm)	59	59	59	59	59	
4.32 Ground clearance centre of wheelbase	m2 (mm)	76	76	76	76	76	
4.33 Aisle width with pallets 1000 x 1200 crosswise	Ast (mm)	3111	3258	3406	3111	3258	
4.34 Aisle width with pallets 800 x 1200 lengthwise	Ast (mm)	3227	3374	3522	3227	3374	
4.35 Turning radius	Wa (mm)	1560	1707	1855	1560	1707	
Performance	5.1 Travel speed with/without load	Km/h	4.8 / 5	4.8 / 5	4.8 / 5	5.5 / 6	5.5 / 6
	5.2 Lift speed with/without load	m/s	0,26 / 0,28	0,20 / 0,28	0,18 / 0,28	0,26 / 0,28	0,20 / 0,28
	5.3 Lowering speed with/without load	m/s	0,20 / 0,34	0,20 / 0,34	0,20 / 0,34	0,20 / 0,34	0,20 / 0,34
	5.8 Max. gradeability, with/without load	%	11 / 11	10 / 10	9 / 9	11/11	10 / 10
	5.10 Service brake		electr / e.magn	electr / e.magn	electr / e.magn	electr / e.magn	electr / e.magn
Power Unit	6.1 Drive motor, S2 60 minute rating	kW	4	4	4	4	4
	6.2 Lifting motor, S3 10% rating	kW	3	3	3	3	3
	6.3 Battery DIN 43531/35/36 A,B,C, no		no	no	no	no	no
	6.4 Battery voltage/capacity at 5 hour rate	V/Ah	24 / 300 *	24 / 400	24 / 400	24 / 300 *	24 / 400
	6.5 Battery weight	kg	260	330	330	260	330
	6.6 VDI Cycle energy	Kwh/h	1,46	1,88	2,29	2,61	3,25
	Vibrations according to EN 13059	m/sec ²	< 2.5	< 2.5	< 2.5	< 4.3	< 4.3
Other	8.1 Drive control		AC - MOSFET	AC - MOSFET	AC - MOSFET	AC - MOSFET	AC - MOSFET
	8.4 Average noise level according to EN 12053	dB(A)	< 70	< 70	< 70	< 70	< 70

* MC10 = available with 400Ah battery .

** Only with Stand On version (min inside dimension 2000mm).

(1) 2 stage mast LFL

(2) 35 / 100 / 1200 mm option

(3) Reverse tiller on Stand On version. Longer tiller on all versions.